

System 1738® Concentric Vent Termination Kit Installation Instructions

⚠ WARNING

Do NOT mix pipe, fittings, cements, or joining methods from different manufacturers, this can result in unsafe conditions and will void the certification and the product warranty.

System1738 Pipe, Fittings, Termination Kits and Cements are certified as a system and must be installed as such.

System1738 PVC concentric termination kits are made from a UL1738 certified PVC compound and are rated to a maximum temperature of 149°F.

All termination kits must be located and installed in accordance with the installation instructions found in this guide and with the local building code and NFPA 54 / ANSI Z223.1 National Fuel Gas Code.

Concentric Vent Kit Installation Considerations

1. Kits must be securely fastened to structure, to ensure clearance dimensions are maintained. Refer to Figures 1 - 4 for installation clearances in different installation scenarios.
2. Straps are field supplied. Use straps, clamps or equivalent that will not score or damage the pipe. Termination support must allow movement as a result of expansion and contraction.
3. All penetrations must be sealed according to local building codes. Caulking for side wall terminations and flashing for roof penetrations are typical. Use only PVC compatible sealing material. Contact the Sealant manufacturer for confirmation on compatibility with PVC.

Figure 1

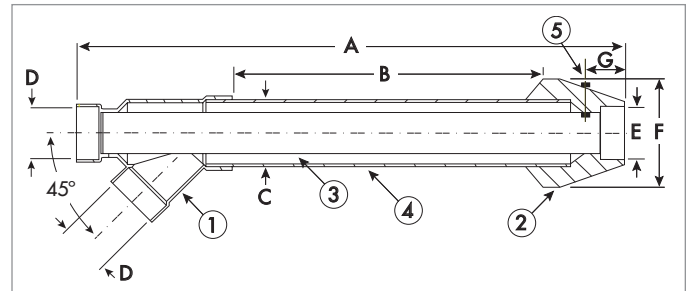

Each Kit Contains:

| Item Description |
|----------------------------|
| Concentric Vent Wye |
| Exhaust Pipe |
| Intake Pipe |
| Rain Cap |
| Stainless Bolt and Locknut |

4. The weight of the concentric kits must be supported by the clamps/straps and not by the vent system it connects to.
5. Insulating exhaust piping in unconditioned space to prevent freezing may be required by the local building code.
6. The pipe length of the concentric vent kit can be shortened, provided that the cutting and welding procedures adhere to the System1738 guidelines outlined in this guide.
NOTE: THE PIPE LENGTH OF THE CONCENTRIC VENT KIT CANNOT BE LENGTHENED.
7. Pipe lengths and/or fittings shall NOT be solvent welded to the socket of the rain cap in order to divert or extend the exhaust gas, unless the appliance manufacture guidelines confirm that the extra length or the changing in direction will not adversely impact the flow of flue gas.

| Concentric Vent Termination Kits Include: | | | Dimension (Inches) | | | | | | |
|---|----------------|--------|--------------------|------|------|-------------------|---|-------|------|
| Material | Concentric Kit | Item # | A | B* | C= | Nominal Pipe Size | | F | G |
| | | | | | | D | E | | |
| PVC | 2" x 16" | 397005 | 29.0 | 16.5 | 3.5 | 2 | 2 | 7.38 | 1.75 |
| PVC | 2" x 28" | 397105 | 41.0 | 28.0 | 3.5 | 2 | 2 | 7.38 | 1.75 |
| PVC | 2" x 40" | 397125 | 53.0 | 40.0 | 3.5 | 2 | 2 | 7.38 | 1.75 |
| PVC | 3" x 20" | 397006 | 36.1 | 20.0 | 4.5 | 3 | 3 | 8.75 | 2.25 |
| PVC | 3" x 32" | 397106 | 48.1 | 32.0 | 4.5 | 3 | 3 | 8.75 | 2.25 |
| PVC | 3" x 44" | 397116 | 60.1 | 44.0 | 4.5 | 3 | 3 | 8.75 | 2.25 |
| PVC | 4" x 36" | 397021 | 56.0 | 37.3 | 6.62 | 4 | 4 | 10.00 | 3.50 |

- 1 Wye - (Concentric)
- 2 Rain Cap
- 3 Exhaust Vent Pipe (Inner)
- 4 Fresh Air Intake Pipe (Outer)
- 5 Stainless Steel Bolt & Nut

B* Dimension may be shortened to a minimum of 12". Inner pipe (item 3) must remain "F" inches longer than the outer pipe (item 4). Cut pipe ends square and solvent weld as outlined in the guide.

C= Installation cutout should be at least 1/2" larger than dimension "C".

DO NOT LENGTHEN THE CONCENTRIC TERMINATION UNITS.



IPEX

by aliaxis

Concentric Vent Kit Assembly

1. Once the installer has determined the termination location, cut a hole in the roof or wall 1/2" larger than the " C " dimension referenced in the previous table for the part being installed. The size of the hole can vary greatly depending on the roof pitch.
2. As per the procedures outlined in this guide, solvent weld the inner pipe to the concentric wye fitting.
3. Solvent weld the outer pipe to the concentric wye fitting.
4. Slide the assembly through the roof or wall penetration. (Install flashing if needed).
5. The outer pipe shall be only a friction fit with the cap. To permanently affix the rain cap, apply solvent cement to the inner pipe as per the procedures outlined in this guide. For installations where removal of the cap may be required for service of the termination or cleaning the cap, it can be fastened mechanically (Drill location reference 5 in Figure 1).
6. Once the rain cap is installed, and the kit secured as outlined below in Figure 2, the kit can be connected to the venting system.

Figure 2: Typical Concentric Vent Side Wall Termination

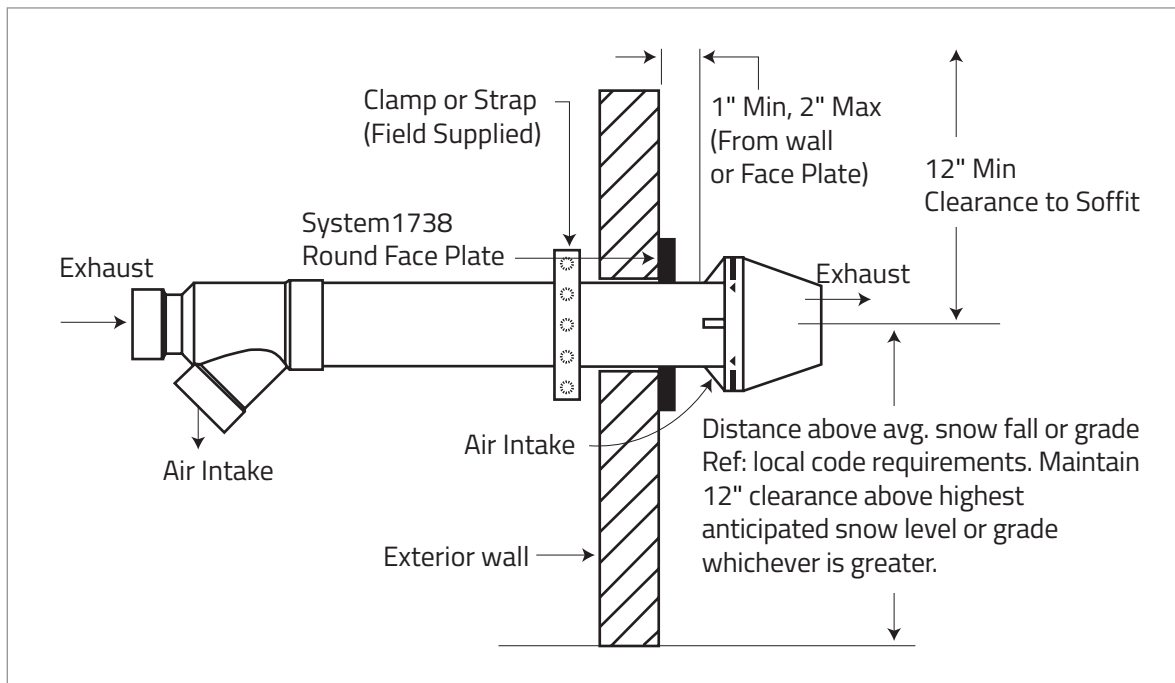

Figure 3: Typical Concentric Vent Pitched Roof Termination

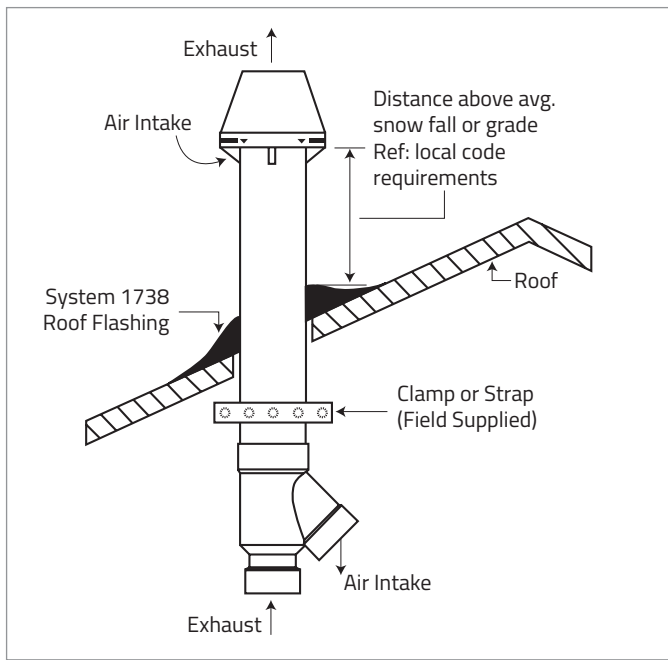
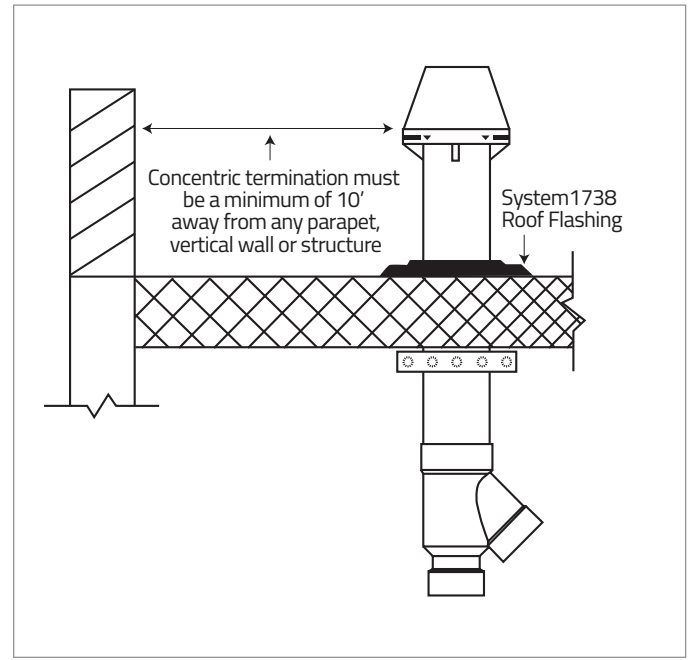

Figure 4: Typical Concentric Vent Flat Roof Termination



Multiple Concentric Vent Kit Spacing

For multiple horizontal and vertical concentric vent kit installations, retain a minimum spacing of 12" between the outside edges of each concentric vent kit as shown in Figures 5 and 6.

These guidelines are not appliance specific actions; appliance manufacturers may supply spacing dimension specific to each appliance. In this case the manufacturer's recommendations shall supersede those described herein.

Figure 5: Multiple Concentric Vent Terminations: HORIZONTAL

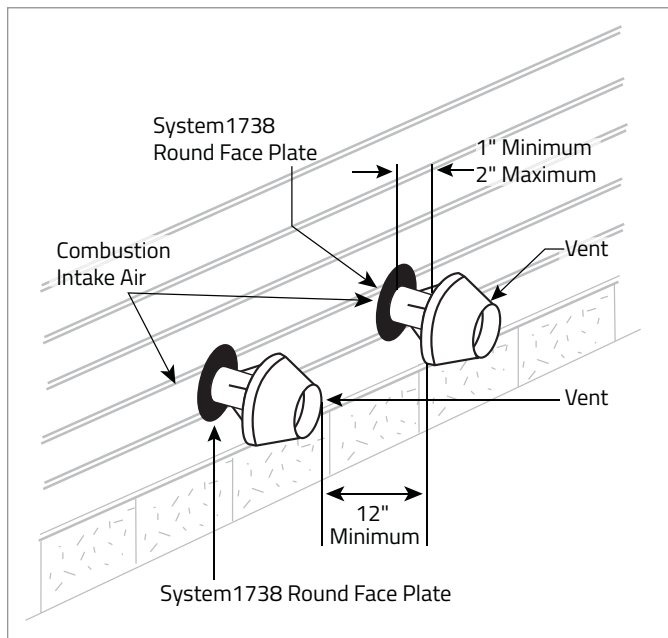
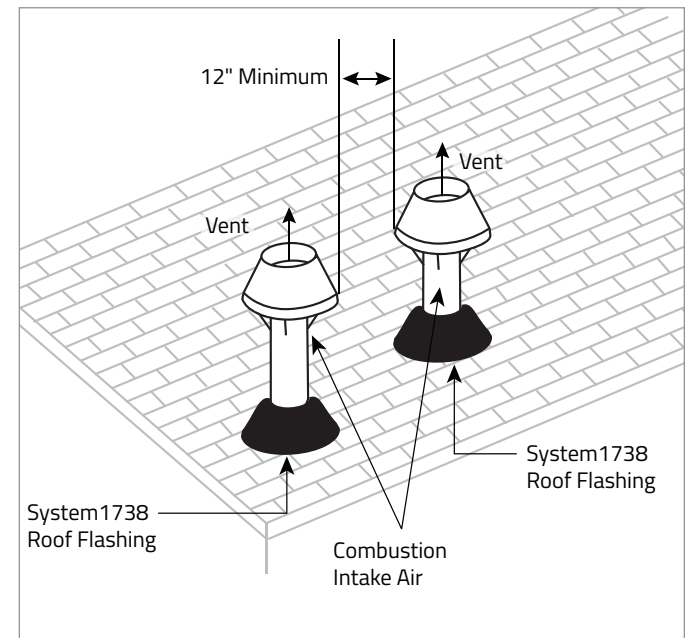

Figure 6: Multiple Concentric Vent Terminations: VERTICAL



Mechanically Fastened Rain Cap

The Rain Cap must be installed with the supplied Stainless Steel bolt and lock nut, and in accordance with the following instructions and diagram (Figure 7).

1. Locate the drill location dimple on the outside of the rain cap. (drill location reference 5 in Figure 7)
2. At this location, drill through the cap and the inner pipe wall. Ensure that the path of the hole is perpendicular to the inner pipe NOT the outside of the cap. For the 2" & 3" kit, drill a 3/16" hole, for the 4" kit, a 1/4" hole.
3. Insert the bolt and tighten the lock nut supplied with the Concentric Vent Kit. Do not over tighten (do NOT use field supplied screws).

Figure 7

