



THERM-X-TROL®

Thermal Expansion Tanks: Diaphragm ST-C Series ASME

150 PSIG Working Pressure

Construction

Shell	Steel
Diaphragm	Heavy Duty Buty NSF/ANSI 61
Liner	Polypropylene
System Connection	Stainless Steel
Finish	Red Oxide Primer
Air Valve	Schrader Valve w/ EPDM Seat
Factory Precharge	55 PSIG (3.8 bar)

Application

- For use in closed, potable water systems to control pressure build-up.
- Fixed diaphragm construction.
- Designed and constructed per ASME Code Section VIII, Division 1.
- All models available with optional sight glass.
- Seismic restraints available on stand models only.

Performance

Maximum Operating Temperature	200°F (93°C)
Maximum Working Pressure	150 PSIG (10.3 bar)
Warranty	1 Year

In-Line Models

Model Number	Tank Volume		Max. Accept. Factor	A Tank Diameter		B Tank Height		System Conn. (NPTM)	Shipping Weight	
	Gal	Lit		In	mm	In	mm		Lbs	Kg
ST-5C	2.0	8	.45	8	203	14	356	3/4	10	5
ST-12C	6.4	24	.50	12	305	18	457	3/4	17	8

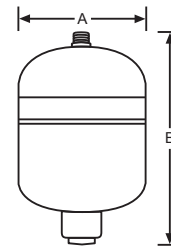

Stand Models

Model Number	Tank Volume		Max. Accept. Factor	A Tank Diameter		B Tank Height		System Conn. (NPTF)	Shipping Weight	
	Gal	Lit		In	mm	In	mm		Lbs	Kg
ST-20VC	8	30	.40	12	305	19	483	3/4	41	19
ST-30VC	14	53	.64	16	406	19	483	3/4	59	27
ST-42VC	18	68	.61	16	406	24	610	3/4	71	32
ST-60VC	25	95	.44	16	406	32	813	3/4	85	39
ST-70VC	34	129	.32	16	406	45	1143	3/4	99	45
ST-80VC	53	201	.66	24	610	37	940	1 1/4	224	102
ST-120VC	68	257	.51	24	610	44	1118	1 1/4	266	121
ST-180VC	77	291	.45	24	610	49	1245	1 1/4	285	129
ST-210VC	90	341	.39	24	610	57	1448	1 1/4	319	145

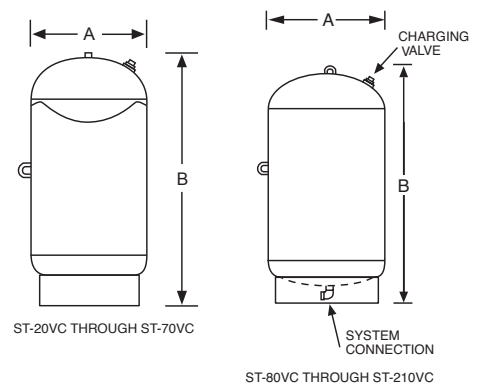

All dimensions and weights are approximate.

Job Name _____	Notes _____
Engineer _____	_____
Contractor _____	_____
P.O. No. _____	_____
Sales Rep. _____	_____
Model No. _____	_____





THERM-X-TROL®

Thermal Expansion Tanks: ST-C Series ASME

175 PSIG Working Pressure

Construction

Shell	Steel
Diaphragm	Heavy Duty Butyl NSF/ANSI 61
Liner	Polypropylene
System Connection	Stainless Steel
Finish	Red Oxide Primer
Air Valve	3/16 Shrader Valve with EPDM Seat
Factory Precharge	55 PSIG (3.8 bar)

Application

- For use in closed, potable water systems to control pressure build-up.
- Fixed diaphragm construction.
- Designed and constructed per ASME Code Section VIII, Division 1.
- All models available with optional sight glass.
- Seismic restraints available on stand models only.

Performance

Maximum Operating Temperature	200°F (93°C)
Maximum Working Pressure	175 PSIG (12 bar)
Warranty	1 Year

In-Line Models

Model Number	Tank Volume		Max. Acceptance Factor	A Tank Diameter		B Tank Height		System Connection (NPTM)	Shipping Weight	
	Gal	Lit		In	mm	In	mm		In	Lbs
ST-5C	2.0	8	.45	8	203	14	356	3/4	12	5
ST-12C	6.4	24	.50	12	305	18	457	3/4	19	9

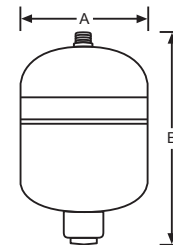

Stand Models

Model Number	Tank Volume		Max. Acceptance Factor	A Tank Diameter		B Tank Height		System Connection (NPTF)	Shipping Weight	
	Gal	Lit		In	mm	In	mm		In	Lbs
ST-20VC	8	30	.40	12	305	19	483	3/4	43	20
ST-30VC	14	53	.64	16	406	19	483	3/4	64	29
ST-42VC	18	68	.61	16	406	24	610	3/4	75	34
ST-60VC	25	95	.44	16	406	32	813	3/4	113	51
ST-70VC	34	129	.32	16	406	45	1143	3/4	122	55
ST-80VC	53	201	.66	24	610	37	940	1 1/4	296	134
ST-120VC	68	257	.51	24	610	44	1118	1 1/4	340	154
ST180VC	77	291	.45	24	610	49	1245	1 1/4	360	163
ST-210VC	90	341	.39	24	610	57	1448	1 1/4	380	172

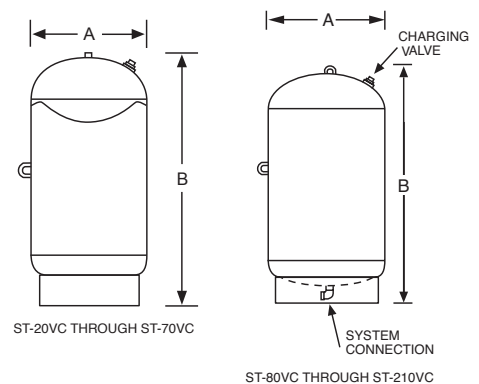

All dimensions and weights are approximate.

Job Name _____	Notes _____
Engineer _____	_____
Contractor _____	_____
P.O. No. _____	_____
Sales Rep. _____	_____
Model No. _____	_____





THERM-X-TROL®

Thermal Expansion Tanks: ST-C Series ASME

250 PSIG Working Pressure

Construction

Shell	Steel
Diaphragm	Heavy Duty Butyl NSF/ANSI 61
Liner	Polypropylene
System Connection	Stainless Steel
Finish	Red Oxide Primer
Air Valve	3/16 Shrader Valve with EPDM Seat
Factory Precharge	55 PSIG (3.8 bar)

Application

- For use in closed, potable water systems to control pressure build-up.
- Fixed diaphragm construction.
- Designed and constructed per ASME Code Section VIII, Division 1.
- All models available with optional sight glass.
- Seismic restraints available on stand models only.

Performance

Maximum Operating Temperature	200°F (93°C)
Maximum Working Pressure	250 PSIG (17.2 bar)
Warranty	1 Year

In-Line Models

Model Number	Tank Volume		Max. Acceptance Factor	A Tank Diameter		B Tank Height		System Connection (NPTF)	Shipping Weight	
	Gal	Lit		In	mm	In	mm		Lbs	Kg
ST-5C	2.1	8	.43	10	254	10	254	3/4	25	11
ST-12C	6.4	24	.50	12	305	14	356	3/4	42	19

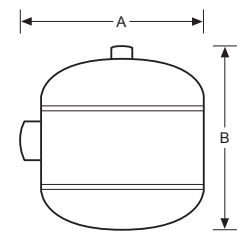

ST-5C & ST-12C
250 & 300 PSI

Stand Models

Model Number	Tank Volume		Max. Acceptance Factor	A Tank Diameter		B Tank Height		System Connection (NPTF)	Shipping Weight	
	Gal	Lit		In	mm	In	mm		Lbs	Kg
ST-20VC	8	30	.40	12	305	19	483	3/4	50	23
ST-30VC	14	53	.64	16	406	19	483	3/4	96	44
ST-42VC	18	68	.61	16	406	24	610	3/4	101	46
ST-60VC	25	95	.44	16	406	32	813	3/4	125	57
ST-70VC	34	129	.32	16	406	45	1143	3/4	136	62
ST-80VC	53	201	.66	24	610	37	940	1 1/4	305	138
ST-120VC	68	257	.51	24	610	44	1118	1 1/4	375	170
ST-180VC	77	291	.45	24	610	49	1245	1 1/4	380	172
ST-210VC	90	341	.39	24	610	57	1448	1 1/4	405	184

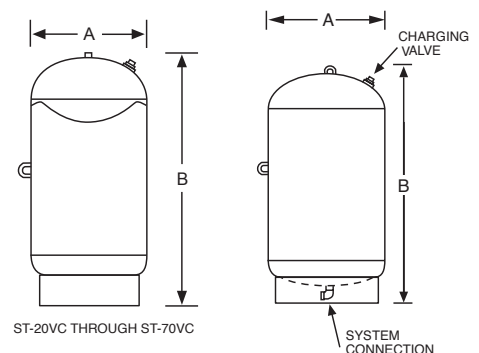

ST-20VC THROUGH ST-70VC

ST-80VC THROUGH ST-210VC

All dimensions and weights are approximate.

Job Name _____	Notes _____
Engineer _____	_____
Contractor _____	_____
P.O. No. _____	_____
Sales Rep. _____	_____
Model No. _____	_____





THERM-X-TROL®

Thermal Expansion Tanks: ST-C Series ASME

300 PSIG Working Pressure

Construction

Shell	Steel
Diaphragm	Heavy Duty Butyl NSF/ANSI 61
Liner	Polypropylene
System Connection	Stainless Steel
Finish	Red Oxide Primer
Air Valve	Schrader Valve w/ EPDM Seat
Factory Precharge	55 PSIG (3.8 bar)

Performance

Maximum Operating Temperature	200°F (93°C)
Maximum Working Pressure	300 PSIG (20.7 bar)
Warranty	1 Year

Application

- For use in closed, potable water systems to control pressure build-up.
- Fixed diaphragm construction.
- Designed and constructed per ASME Code Section VIII, Division 1.
- All models available with optional sight glass.
- Seismic restraints available on stand models only.

In-Line Models

Model Number	Tank Volume		Max. Acceptance Factor	A Tank Diameter		B Tank Height		System Connection (NPTF)	Shipping Weight	
	Gal	Lit		In	mm	In	mm		Lbs	Kg
ST-5C	2.1	8	.45	10	254	10	254	3/4	30	14
ST-12C	6.4	24	.50	12	305	14	356	3/4	50	23

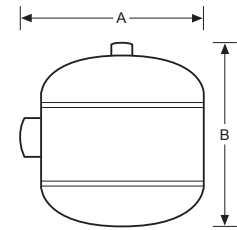

ST-5C & ST-12C
250 & 300 PSI

Stand Models

Model Number	Tank Volume		Max. Acceptance Factor	A Tank Diameter		B Tank Height		System Connection (NPTF)	Shipping Weight	
	Gal	Lit		In	mm	In	mm		Lbs	Kg
ST-20VC	8	30	.40	12	305	19	483	3/4	62	28
ST-30VC	14	53	.64	16	406	19	483	3/4	108	49
ST-42VC	18	68	.61	16	406	24	610	3/4	112	51
ST-60VC	25	95	.44	16	406	32	813	3/4	139	63
ST-70VC	34	129	.32	16	406	45	1143	3/4	151	68
ST-80VC	53	201	.66	24	610	37	940	1 1/4	340	154
ST-120VC	68	257	.51	24	610	44	1118	1 1/4	400	181
ST-180VC	77	291	.45	24	610	49	1245	1 1/4	420	191
ST-210VC	90	341	.39	24	610	57	1448	1 1/4	440	200

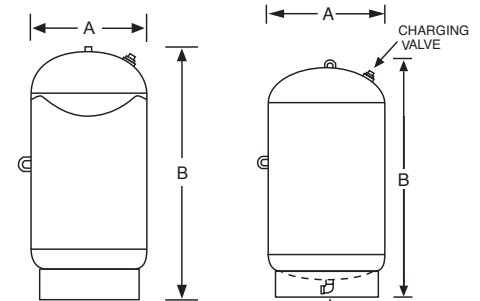

ST-20VC THROUGH ST-70VC

ST-80VC THROUGH ST-210VC

All dimensions and weights are approximate.

Job Name _____	Notes _____
Engineer _____	_____
Contractor _____	_____
P.O. No. _____	_____
Sales Rep. _____	_____
Model No. _____	_____





THERM-X-TROL®

Thermal Expansion: Full Acceptance Bladder ST-440C and ST-450C Series ASME

125 PSIG Working Pressure

Construction

Shell	Steel
Bladder Material	Heavy Duty Butyl NSF/ANSI 61
Bladder Thickness	.100 In Minimum
System Connection	Bronze
Finish	Red Oxide Primer
Air Valve	Schrader Valve w/ EPDM Seat
Factory Precharge	55 PSIG (3.8 bar)

Performance

Maximum Operating Temperature	240°F (115°C)
Maximum Working Pressure	125 PSIG (8.6 bar)
Warranty	1 Year

Application

- For use in closed, potable water systems to control pressure build-up.
- Full acceptance replaceable bladder design.
- Optional sight glass and seismic restraints available.
- Designed and constructed per ASME Code Section VIII, Division 1.

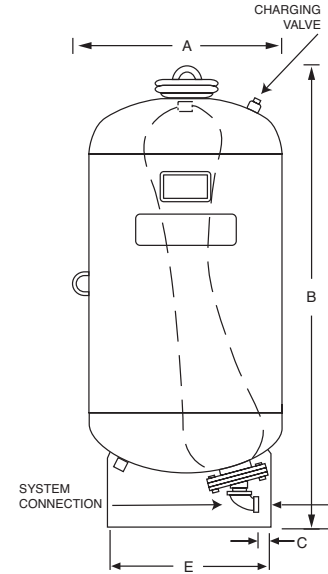

ASME Models

Model Number	Tank Volume		Max. Accept. Factor	A Tank Diameter		B Tank Height		C System Conn. Height		D Conn. Centerline		E Stand Diameter		System Conn. (NPTF)	Shipping Weight	
	Gal	Lit		In	mm	In	mm	In	mm	In	mm	In	mm		Lbs	Kg
ST-447C	53	200	1.0	24	610	45	1143	2	51	3¾	95	19	483	2	236	107
ST-448C	80	300	1.0	24	610	59	1498	2	51	3¾	95	19	483	2	274	124
ST-449C	106	400	1.0	24	610	73	1854	2	51	3¾	95	19	483	2	320	145
ST-450C	132	500	1.0	24	610	87	2210	2	51	3¾	95	19	483	2	354	161
ST-451C	158	600	1.0	30	762	73	1854	3½	89	5½	140	24	610	2	494	224
ST-452C	211	800	1.0	30	762	91	2311	3½	89	5½	140	24	610	2	593	269
ST-453C	264	1000	1.0	36	914	86	2184	4½	114	7	178	30	762	3	667	303
ST-454C	317	1200	1.0	36	914	98	2438	4½	114	7	178	30	762	3	762	346
ST-455C	370	1400	1.0	36	914	110	2794	4½	114	7	178	30	762	3	842	382
ST-456C	422	1600	1.0	48	1219	82	2083	7½	191	7⅞	178	42	1067	3	1152	523
ST-457C	528	2000	1.0	48	1219	97	2464	7½	191	7⅞	178	42	1067	3	1335	606

All dimensions and weights are approximate.

Job Name _____	Notes _____
Engineer _____	_____
Contractor _____	_____
P.O. No. _____	_____
Sales Rep. _____	_____
Model No. _____	_____





THERM-X-TROL®

Thermal Expansion: Full Acceptance Bladder ST-440C and ST-450C Series ASME

150 PSIG Working Pressure

Construction

Shell	Steel
Bladder Material	Heavy Duty Butyl NSF/ANSI 61
Bladder Thickness	.100 In Minimum
System Connection	Bronze
Finish	Red Oxide Primer
Air Valve	Schrader Valve w/ EPDM Seat
Factory Precharge	55 PSIG (3.8 bar)

Performance

Maximum Operating Temperature	240°F (115°C)
Maximum Working Pressure	150 PSIG (10.3 bar)
Warranty	1 Year

Application

- For use in closed, potable water systems to control pressure build-up.
- Full acceptance replaceable bladder design.
- Optional sight glass and seismic restraints available.
- Designed and constructed per ASME Code Section VIII, Division 1.

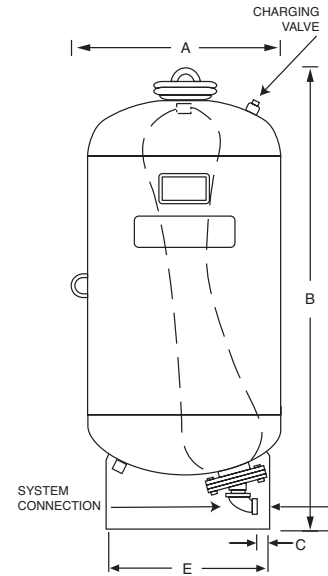

ASME Models

Model Number	Tank Volume		Max. Accept. Factor	A Tank Diameter		B Tank Height		C System Conn. Height		D Conn. Centerline		E Stand Diameter		System Conn. (NPTF)	Shipping Weight	
	Gal	Lit		In	mm	In	mm	In	mm	In	mm	In	mm		Lbs	Kg
ST-447C	53	200	1.0	24	610	45	1143	2	51	3¾	95	19	483	2	262	119
ST-448C	80	300	1.0	24	610	59	1498	2	51	3¾	95	19	483	2	340	154
ST-449C	106	400	1.0	24	610	73	1854	2	51	3¾	95	19	483	2	360	163
ST-450C	132	500	1.0	24	610	87	2210	2	51	3¾	95	19	483	2	400	181
ST-451C	158	600	1.0	30	762	73	1854	3½	89	5½	140	24	610	2	587	266
ST-452C	211	800	1.0	30	762	91	2311	3½	89	5½	140	24	610	2	625	283
ST-453C	264	1000	1.0	36	914	86	2184	4½	114	7	178	30	762	3	760	345
ST-454C	317	1200	1.0	36	914	98	2438	4½	114	7	178	30	762	3	850	386
ST-455C	370	1400	1.0	36	914	110	2794	4½	114	7	178	30	762	3	935	424
ST-456C	422	1600	1.0	48	1219	82	2083	7½	191	7⅞	178	42	1067	3	1423	645
ST-457C	528	2000	1.0	48	1219	97	2464	7½	191	7⅞	178	42	1067	3	1505	683

All dimensions and weights are approximate.

Job Name _____	Notes _____
Engineer _____	_____
Contractor _____	_____
P.O. No. _____	_____
Sales Rep. _____	_____
Model No. _____	_____





THERM-X-TROL®

Thermal Expansion: Full Acceptance Bladder ST-440C and ST-450C Series ASME

175 PSIG Working Pressure

Construction

Shell	Steel
Bladder Material	Heavy Duty Butyl NSF/ANSI 61
Bladder Thickness	.100 In Minimum
System Connection	Bronze
Finish	Red Oxide Primer
Air Valve	Schrader Valve w/ EPDM Seat
Factory Precharge	55 PSIG (3.8 bar)

Performance

Maximum Operating Temperature	240°F (115°C)
Maximum Working Pressure	175 PSIG (12 bar)
Warranty	1 Year

Application

- For use in closed, potable water systems to control pressure build-up.
- Full acceptance replaceable bladder design.
- Optional sight glass and seismic restraints available.
- Designed and constructed per ASME Code Section VIII, Division 1.

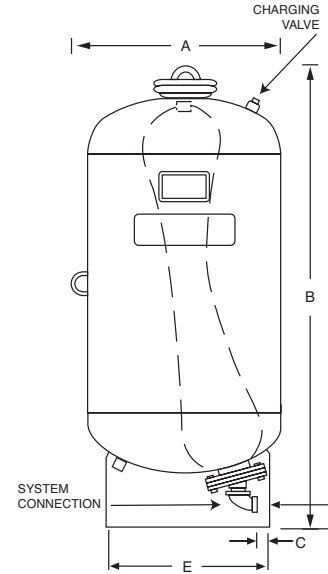

ASME Models

Model Number	Tank Volume		Max. Accept. Factor	A Tank Diameter		B Tank Height		C System Conn. Height		D Conn. Centerline		E Stand Diameter		System Conn. (NPTF)	Shipping Weight	
	Gal	Lit		In	mm	In	mm	In	mm	In	mm	In	mm		In	Lbs
ST-447C	53	200	1.0	24	610	45	1143	2	51	3¾	95	19	483	2	290	132
ST-448C	80	300	1.0	24	610	59	1498	2	51	3¾	95	19	483	2	430	195
ST-449C	106	400	1.0	24	610	73	1854	2	51	3¾	95	19	483	2	450	204
ST-450C	132	500	1.0	24	610	87	2210	2	51	3¾	95	19	483	2	460	209
ST-451C	158	600	1.0	30	762	73	1854	3½	89	5½	140	24	610	2	680	308
ST-452C	211	800	1.0	30	762	91	2311	3½	89	5½	140	24	610	2	699	317
ST-453C	264	1000	1.0	36	914	86	2184	4½	114	7	178	30	762	3	845	384
ST-454C	317	1200	1.0	36	914	98	2438	4½	114	7	178	30	762	3	960	435
ST-455C	370	1400	1.0	36	914	110	2794	4½	114	7	178	30	762	3	1065	483
ST-456C	422	1600	1.0	48	1219	82	2083	7½	191	7⅞	178	42	1067	3	1650	748
ST-457C	528	2000	1.0	48	1219	97	2464	7½	191	7⅞	178	42	1067	3	1875	850

All dimensions and weights are approximate.

Job Name _____	Notes _____
Engineer _____	_____
Contractor _____	_____
P.O. No. _____	_____
Sales Rep. _____	_____
Model No. _____	_____





THERM-X-TROL®

Thermal Expansion: Full Acceptance Bladder ST-440C and ST-450C Series ASME

250 PSIG Working Pressure

Construction

Shell	Steel
Bladder Material	Heavy Duty Butyl NSF/ANSI 61
Bladder Thickness	.100 In Minimum
System Connection	Bronze
Finish	Red Oxide Primer
Air Valve	Schrader Valve w/ EPDM Seat
Factory Precharge	55 PSIG (3.8 bar)

Performance

Maximum Operating Temperature	240°F (115°C)
Maximum Working Pressure	250 PSIG (17.2 bar)
Warranty	1 Year

Application

- For use in closed, potable water systems to control pressure build-up.
- Full acceptance replaceable bladder design.
- Optional sight glass and seismic restraints available.
- Designed and constructed per ASME Code Section VIII, Division 1.

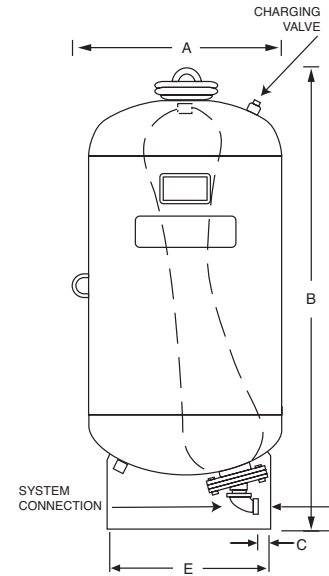

ASME Models

Model Number	Tank Volume		Max. Accept. Factor	A Tank Diameter		B Tank Height		C System Conn. Height		D Conn. Centerline		E Stand Diameter		System Conn. (NPTF)	Shipping Weight	
	Gal	Lit		In	mm	In	mm	In	mm	In	mm	In	mm		Lbs	Kg
ST-447C	53	200	1.0	24	610	45	1143	2	51	3¾	95	19	483	2	370	168
ST-448C	80	300	1.0	24	610	59	1498	2	51	3¾	95	19	483	2	492	223
ST-449C	106	400	1.0	24	610	73	1854	2	51	3¾	95	19	483	2	510	231
ST-450C	132	500	1.0	24	610	87	2210	2	51	3¾	95	19	483	2	570	259
ST-451C	158	600	1.0	30	762	73	1854	3½	89	5½	140	24	610	2	815	370
ST-452C	211	800	1.0	30	762	91	2311	3½	89	5½	140	24	610	2	1005	456
ST-453C	264	1000	1.0	36	914	86	2184	4½	114	7	178	30	762	3	1100	499
ST-454C	317	1200	1.0	36	914	98	2438	4½	114	7	178	30	762	3	1265	574
ST-455C	370	1400	1.0	36	914	110	2794	4½	114	7	178	30	762	3	1350	612
ST-456C	422	1600	1.0	48	1219	82	2083	7½	191	7⅞	178	42	1067	3	1660	753
ST-457C	528	2000	1.0	48	1219	97	2464	7½	191	7⅞	178	42	1067	3	2230	1012

All dimensions and weights are approximate.

Job Name _____	Notes _____
Engineer _____	_____
Contractor _____	_____
P.O. No. _____	_____
Sales Rep. _____	_____
Model No. _____	_____





THERM-X-TROL®

Thermal Expansion: Full Acceptance Bladder ST-440C and ST-450C Series ASME

300 PSIG Working Pressure

Construction

Shell	Steel
Bladder Material	Heavy Duty Butyl NSF/ANSI 61
Bladder Thickness	.100 In Minimum
System Connection	Bronze
Finish	Red Oxide Primer
Air Valve	Schrader Valve w/ EPDM Seat
Factory Precharge	55 PSIG (3.8 bar)

Performance

Maximum Operating Temperature	240°F (115°C)
Maximum Working Pressure	300 PSIG (20.7 bar)
Warranty	1 Year

Application

- For use in closed, potable water systems to control pressure build-up.
- Full acceptance replaceable bladder design.
- Optional sight glass and seismic restraints available.
- Designed and constructed per ASME Code Section VIII, Division 1.

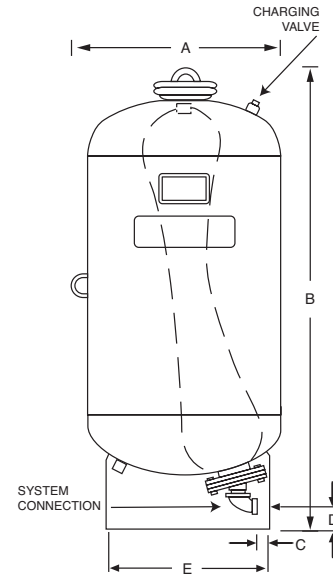

ASME Models

Model Number	Tank Volume		Max. Accept. Factor	A Tank Diameter		B Tank Height		C System Conn. Height		D Conn. Centerline		E Stand Diameter		System Conn. (NPTF)	Shipping Weight	
	Gal	Lit		In	mm	In	mm	In	mm	In	mm	In	mm		In	Lbs
ST-447C	53	200	1.0	24	610	45	1143	2	51	3¾	95	19	483	2	425	193
ST-448C	80	300	1.0	24	610	59	1498	2	51	3¾	95	19	483	2	540	245
ST-449C	106	400	1.0	24	610	73	1854	2	51	3¾	95	19	483	2	560	254
ST-450C	132	500	1.0	24	610	87	2210	2	51	3¾	95	19	483	2	632	287
ST-451C	158	600	1.0	30	762	73	1854	3½	89	5½	140	24	610	2	895	406
ST-452C	211	800	1.0	30	762	91	2311	3½	89	5½	140	24	610	2	1107	502
ST-453C	264	1000	1.0	36	914	86	2184	4½	114	7	178	30	762	3	1205	547
ST-454C	317	1200	1.0	36	914	98	2438	4½	114	7	178	30	762	3	1400	635
ST-455C	370	1400	1.0	36	914	110	2794	4½	114	7	178	30	762	3	1490	676
ST-456C	422	1600	1.0	48	1219	82	2083	7½	191	7⅞	178	42	1067	3	1830	830
ST-457C	528	2000	1.0	48	1219	97	2464	7½	191	7⅞	178	42	1067	3	2455	1114

All dimensions and weights are approximate.

Job Name _____	Notes _____
Engineer _____	_____
Contractor _____	_____
P.O. No. _____	_____
Sales Rep. _____	_____
Model No. _____	_____





THERM-X-TROL®

Thermal Expansion: Full Acceptance Bladder ST-450 Series Non-ASME

150 PSIG Working Pressure

Construction

Shell	Steel
Bladder Material	Heavy Duty Butyl NSF/ANSI 61
Bladder Thickness	.100 In Minimum
System Connection	Bronze
Finish	Red Oxide Primer
Air Valve	Schrader Valve w/ EPDM Seat
Factory Precharge	55 PSIG (3.8 bar)

Performance

Maximum Operating Temperature	240°F (115°C)
Maximum Working Pressure	150 PSIG (10.3 bar)
Warranty	1 Year

Application

- For use in closed, potable water systems to control pressure build-up.
- Full acceptance replaceable bladder design.
- Optional sight glass and seismic restraints available.

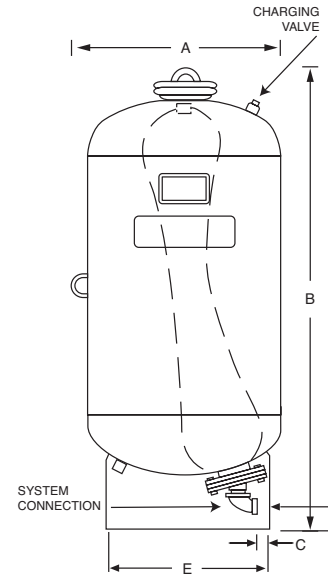

Non-ASME Models

Model Number	Tank Volume		Max. Accept. Factor	A Tank Diameter		B Tank Height		C Sys. Conn. Height		D Conn. Centerline		E Stand Diameter		System Conn. (NPTF)	Shipping Weight	
	Gal	Lit		In	mm	In	mm	In	mm	In	mm	In	mm		Lbs	Kg
ST-451	158	600	1.0	30	762	73	1854	3½	89	5½	140	24	610	2	587	266
ST-452	211	800	1.0	30	762	91	2311	3½	89	5½	140	24	610	2	625	283
ST-453	264	1000	1.0	36	914	86	2184	4½	114	7	178	30	762	3	760	345
ST-454	317	1200	1.0	36	914	98	2438	4½	114	7	178	30	762	3	850	386
ST-455	370	1400	1.0	36	914	110	2794	4½	114	7	178	30	762	3	935	424
ST-456	422	1600	1.0	48	1219	82	2083	7½	191	7⅞	178	42	1067	3	1423	645
ST-457	528	2000	1.0	48	1219	97	2464	7½	191	7⅞	178	42	1067	3	1505	683

All dimensions and weights are approximate.

Job Name _____	Notes _____
Engineer _____	_____
Contractor _____	_____
P.O. No. _____	_____
Sales Rep. _____	_____
Model No. _____	_____





THERM-X-TROL®

Thermal Expansion Tanks: Partial Acceptance Bladder ST Series ASME

150 PSIG Working Pressure

Construction

Shell	Carbon Steel
Bladder Material	Heavy Duty Butyl
Bladder Thickness (models 35-100)	.087 In Minimum
Bladder Thickness (models 130-600)	.100 In Minimum
System Connection	Stainless Steel
Finish	Red Oxide Primer
Air Valve	Schrader Valve w/ EPDM Seat
Factory Precharge	55 PSIG (3.7 bar)

Performance

Maximum Operating Temperature	240°F (115°C)
Maximum Working Pressure	150 PSIG (10.3 bar)
Warranty	1 Year

Application

- For use in closed, potable water systems to control pressure build-up.
- Partial acceptance replaceable bladder design.
- Optional sight glass and seismic restraints available.
- Designed and constructed per ASME Code Section VIII, Division 1.

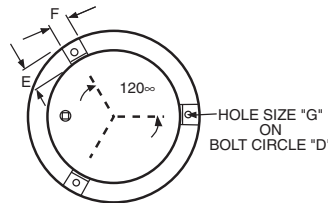
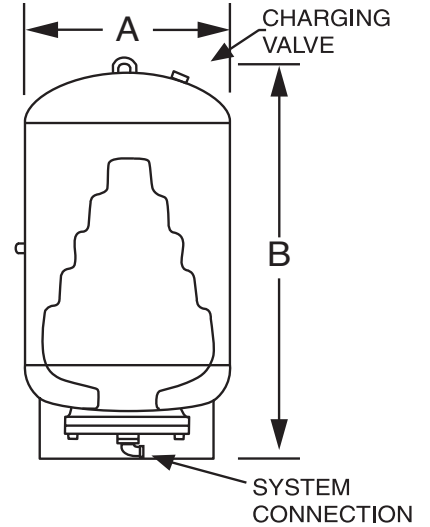

BOTTOM VIEW

ASME Models

Model Number	Tank Volume		Max. Accept. Factor	A Tank Diameter		B Tank Height		System Conn. (NPTF)	Shipping Weight	
	Gal	Lit		In	mm	In	mm		Lbs	Kg
ST-35CL	10	35	1.00	10	254	37	948	1	76	34
ST-50CL	13	50	.85	12	305	37	941	1	78	35
ST-85CL	22	85	.50	16	406	35	872	1	95	43
ST-100CL	26	100	.42	16	406	39	991	1	102	46
ST-130CL	34	130	.79	20	508	35	881	1	134	61
ST-165CL	44	165	.61	20	508	40	1008	1	153	69
ST-200CL	53	200	.51	24	610	41	1039	1	205	93
ST-300CL	80	300	.34	24	610	56	1423	1	254	115
ST-400CL	106	400	.50	24	610	69	1743	1	308	140
ST-500CL	132	500	.40	24	610	83	2096	1	352	160
ST-600CL	158	600	.34	30	762	67	1702	1	442	200

Optional Seismic Restraints

Tank Diameter	Bolt Circle	Dim.	Dim.	Hole Size
B	D	E	F	G
10	12 ⁵ / ₈	2	2	⁹ / ₁₆
12	14 ³ / ₄	2	2	⁹ / ₁₆
16	16 ³ / ₄	2	2	⁹ / ₁₆
20	16 ³ / ₄	2	2	⁹ / ₁₆
24	18	2	2	⁹ / ₁₆
30	22 ³ / ₄	3	3	³ / ₄

All dimensions and weights are approximate.

Job Name _____	Notes _____
Engineer _____	_____
Contractor _____	_____
P.O. No. _____	_____
Sales Rep. _____	_____
Model No. _____	_____





THERM-X-TROL®

Thermal Expansion Tanks: Partial Acceptance Bladder ST Series Non-ASME

150 PSIG Working Pressure

Construction

Shell	Carbon Steel
Bladder Material	Heavy Duty Butyl
Bladder Thickness (models 35-100)	.087 In Minimum
Bladder Thickness (models 130-600)	.100 In Minimum
System Connection	Stainless Steel
Finish	Red Oxide Primer
Air Valve	Schrader Valve w/ EPDM Seat
Factory Precharge	55 PSIG (3.7 bar)

Application

- For use in closed, potable water systems to control pressure build-up.
- Partial acceptance replaceable bladder design.
- Optional sight glass and seismic restraints available.

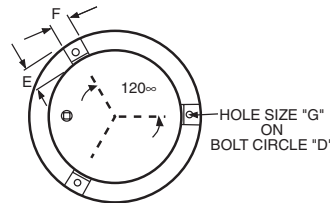
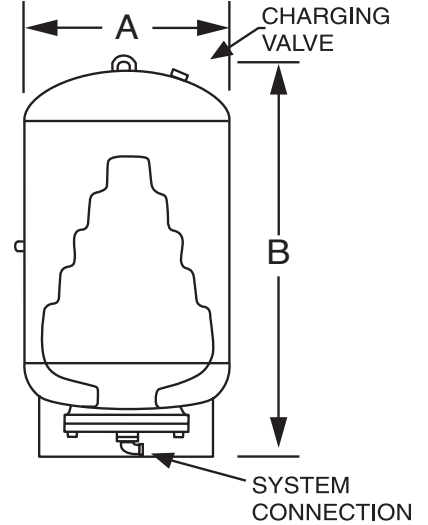

BOTTOM VIEW

Performance

Maximum Operating Temperature	240°F (115°C)
Maximum Working Pressure	150 PSIG (10.3 bar)
Warranty	1 Year

Non-ASME Models

Model Number	Tank Volume		Max. Accept. Factor	A Tank Diameter		B Tank Height		System Conn. (NPTF)	Shipping Weight	
	Gal	Lit		In	mm	In	mm		Lbs	Kg
ST-35L	10	35	1.00	10	254	37	948	1	76	34
ST-50L	13	50	.85	12	305	37	941	1	78	35
ST-85L	22	85	.50	16	406	35	872	1	95	43
ST-100L	26	100	.42	16	406	39	991	1	102	46
ST-130L	34	130	.79	20	508	35	881	1	134	61
ST-165L	44	165	.61	20	508	40	1008	1	153	69
ST-200L	53	200	.51	24	610	41	1039	1	205	93
ST-300L	80	300	.34	24	610	56	1423	1	254	115
ST-400L	106	400	.50	24	610	69	1743	1	308	140
ST-500L	132	500	.40	24	610	83	2096	1	352	160
ST-600L	158	600	.34	30	762	67	1702	1	442	200

Optional Seismic Restraints

Tank Diameter	Bolt Circle	Dim.	Dim.	Hole Size
B	D	E	F	G
10	12 ⁵ / ₈	2	2	9 ¹ / ₁₆
12	14 ³ / ₄	2	2	9 ¹ / ₁₆
16	16 ³ / ₄	2	2	9 ¹ / ₁₆
20	16 ³ / ₄	2	2	9 ¹ / ₁₆
24	18	2	2	9 ¹ / ₁₆
30	22 ³ / ₄	3	3	3 ¹ / ₄

All dimensions and weights are approximate.

Job Name _____	Notes _____
Engineer _____	_____
Contractor _____	_____
P.O. No. _____	_____
Sales Rep. _____	_____
Model No. _____	_____





THERM-X-TROL®

Thermal Expansion Tanks: ST Series Non-ASME

150 PSIG Working Pressure

Construction

Shell	Steel
Diaphragm	Heavy Duty Butyl NSF/ANSI 61
Liner	Antimicrobial
System Connection	Stainless Steel
Finish	Urethane Topcoat
Water Circulator	Turbulator™
Air Valve	Projection Welded
Factory Precharge	In-line Models 50 PSIG (3.5 bar) Stand Models 40 PSIG (2.8 bar)

Application

- For use in closed, potable water systems to control pressure build-up.
- Accepts expanded water as system temperature rises and returns hot water to system when demand occurs.
- Stand models designed for large residential and light commercial applications.
- Multiple units can be installed to accommodate larger systems.

Performance

Maximum Operating Temperature	200°F (93°C)
Maximum Working Pressure	150 PSIG (10.3 bar)
Warranty	1 Year - ST-30V through ST-210V 5 Years - ST-5 through ST-25V

In-Line Models

Model Number	Tank Volume		Max. Acceptance Factor	A Tank Diameter		B Tank Height		System Connection (NPTM)	Shipping Weight	
	Gal	Lit		In	mm	In	mm		Lbs	Kg
ST-5	2.0	8	.45	8	203	13	330	¾	5	2
ST-8	3.2	12	.59	9	229	15	381	¾	7	3
ST-12	4.4	17	.73	11	279	15	381	¾	9	4

Stand Models

Model Number	Tank Volume		Max. Acceptance Factor	A Tank Diameter		B Tank Height		System Connection (NPTF)	Shipping Weight	
	Gal	Lit		In	mm	In	mm		Lbs	Kg
ST-25V	10.3	39	1.00	15	381	19	483	¾	23	10
ST-30V	14.0	53	0.81	15	381	24	610	¾	25	11
ST-42V	20.0	76	0.57	15	381	32	813	¾	33	15
ST-60V	34.0	129	1.00	22	559	30	762	1¼	61	28
ST-80V	44.0	167	0.77	22	559	36	914	1¼	69	31
ST-180V	62.0	235	0.55	22	559	47	1194	1¼	92	42
ST-200V	81.0	307	0.44	22	559	56	1422	1¼	103	47
ST-210V	86.0	326	0.54	26	660	47	1194	1¼	123	56

All dimensions and weights are approximate.

Job Name _____	Notes _____
Engineer _____	_____
Contractor _____	_____
P.O. No. _____	_____
Sales Rep. _____	_____
Model No. _____	_____

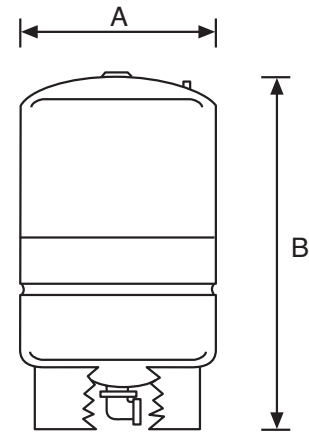
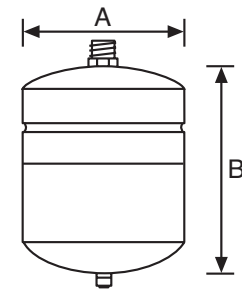



THERM-X-SPAN®

Thermal Expansion Tanks: T Series Non-ASME

150 PSIG Working Pressure

Construction

Shell	Steel
Diaphragm	Heavy Duty Butyl NSF/ANSI 61
Liner	Polypropylene
Finish	Urethane Topcoat
Air Valve	Projection Welded
Factory Precharge	40 PSIG (2.8 bar)

Application

- For use in closed, potable water systems to control pressure build-up.
- Accepts expanded water as system temperature rises and returns hot water to system when demand occurs.
- Multiple units can be installed to accommodate larger systems.

Performance

Maximum Operating Temperature	200°F (93°C)
Maximum Working Pressure	150 PSIG (10.3 bar)
Warranty	1 Year

In-Line Models

Model Number	Tank Volume		Max. Acceptance Factor	A Tank Diameter		B Tank Height		System Connection (NPTM)	Shipping Weight	
	Gal	Lit		In	mm	In	mm		Lbs	Kg
T-5	2.0	8	.45	8	203	13	330	¾	5	2
T-8	3.2	12	.59	9	229	15	381	¾	7	3
T-12	4.4	17	.73	11	279	15	381	¾	9	4

All dimensions and weights are approximate.

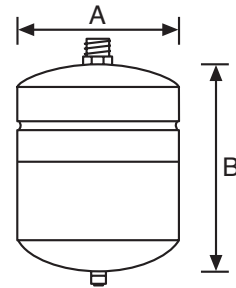

Job Name _____	Notes _____
Engineer _____	_____
Contractor _____	_____
P.O. No. _____	_____
Sales Rep. _____	_____
Model No. _____	_____

