

FSA1BF Series

Extra High Efficiency Air Conditioner 16 SEER Residential System 2 - 5 Ton Capacity

The FSA1BF Series air conditioners offers exceptional performance. The unit, when combined with our engineered coils or air handlers, offers a line of quality, 16 SEER split system cooling equipment.

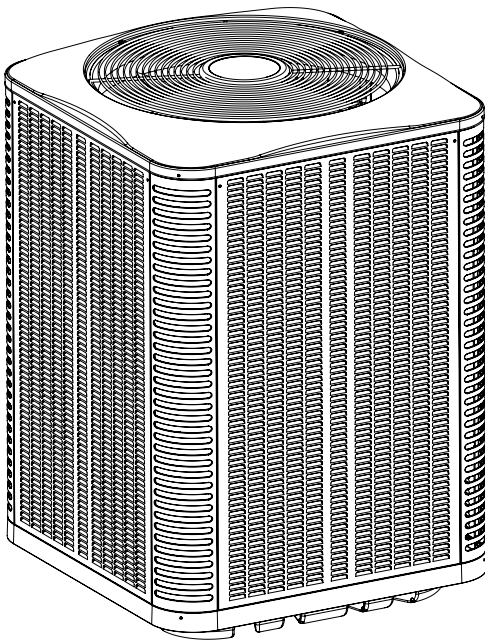

FEATURES and BENEFITS

- **CoreSense™ Compressor Protection** : Control module actively monitors compressor conditions and will shut the unit down to prevent damage.
- **Copeland Scroll UltraTech™ Compressor**: The Ultra Tech Compressor operates with 2 stages of cooling capacity to provide superior comfort and efficiency. Copeland's proven and simple design equates to years of comfort and reliability for the homeowner with virtually silent operation.
- **Designed Using Galvanized Steel**: With a polyester urethane coat finish, it passes 950 hours of salt spray per ASTM Std. B117.
- **Composite Base Pan**: Absorbs sound and is corrosion resistant. Composite is also stronger and lighter than steel.
- **Compressor Sound Blanket**: Engineered to significantly reduce unwanted compressor noise.
- **Swept-Wing Fan Blade**: Designed to significantly reduce unwanted noise.
- **Removable Top Grille Assembly**: Allows ease of service from the top without disconnecting fan motor leads.
- **Low Pressure Switch**: Loss of charge protection ensures long compressor life. Auto-reset feature prevents nuisance service visits.
- **High Pressure Switch**: Protects against abnormally high system pressures. Auto-reset feature prevents nuisance service visits.
- **Liquid Line Filter Drier**: Included with unit, field installed.
- **One Piece Top/Orifice**: Designed for maximum airflow and quiet operation.
- **Easy Compressor and Control Access**: Designed to make servicing easier for the contractor, access panels are provided to all controls and the compressor from the side of the unit.
- **Micro-Channel**: All aluminum coils in all models which provides high corrosion resistance.
- **Service-Friendly Jacket**: Side panels can be easily removed and replaced without removing the top grill.

MODEL IDENTIFICATION CODES

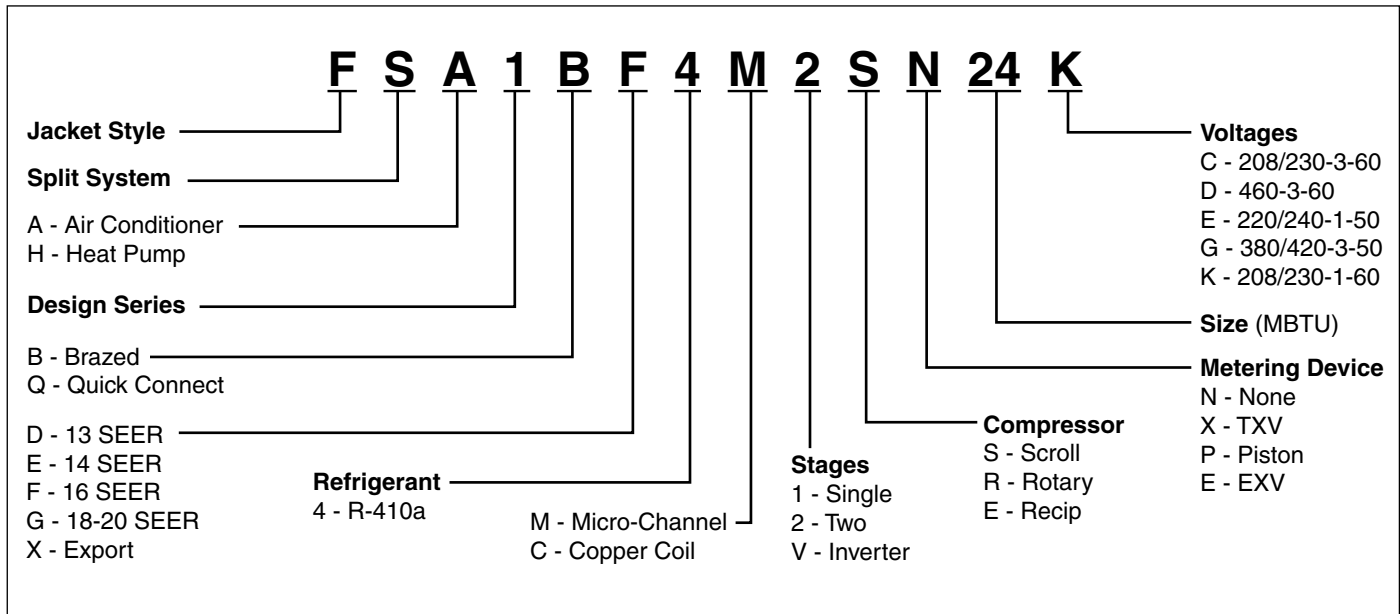

DIMENSIONS

AIR CONDITIONER OUTDOOR SECTION

FSA1BF	24K	36K	48K	60K
H	36.5	37.25	41.25	45.25
W	23.75	31.75	31.75	31.75
D	23.75	31.75	31.75	31.75

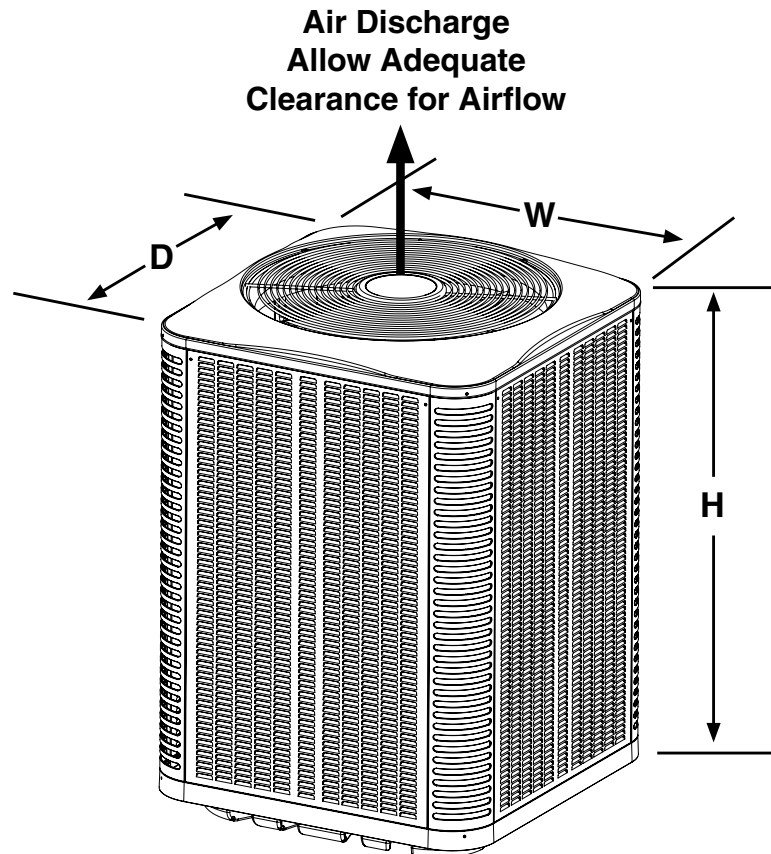

PHYSICAL AND ELECTRICAL SPECIFICATIONS / OUTDOOR UNITS

16 SEER — Extra High Efficiency — Single Phase

Model Number FSA1BF		24K	36K	48K	60K	
Electrical Data	Volts-Cycles-Phase (1)	208/230-60-1				
	Total Amps	12.3	16.5	23.7	31.4	
	Delay Fuse Max. (2)	25	35	50	60	
	Min. Circuit Ampacity	15.3	20.3	29.0	38.6	
Component Data	Fan Motor	Type	PSC		BLDC	
		Amps	0.7	1.3	2.6	2.6
		HP	0.10	0.25	0.33	0.33
	Compressor Data	RLA	11.6	15.2	21.1	28.8
		LRA	58.3	83.0	104.0	152.9
		Refrigerant suction line O.D. NOTE: Liquid line is 3/8" O.D. for entire length.	0-24 ft.	3/4"	7/8"(4)	7/8"
	25-39 ft.	7/8" (3)	1-1/8" (3)	1-1/8" (3)	1-1/8" (3)	
	40-75 ft.	7/8" (3)	1-1/8" (3)	1-1/8" (3)	1-1/8" (3)	
Approximate Weight (lbs.)	Net	133	199	230	251	
	Ship	141	210	242	264	
Sound Ratings db		73	75	76	77	

- (1) Operating Voltage Range: 187v min. - 253v max.
 (2) HACR Type Circuit Breakers may be used.
 (3) Requires 1-1/8" to 7/8" reducer from line to unit.
 (4) Use of a 3/4" linset will result in approximately 2% loss in capacity.
 (5) Additional charge for line sets above 15 feet.
 Values based on suction line as follows with 3/8" liquid line.
 a) 3/4" = 0.6 oz. per additional foot.
 b) 7/8" = 0.7 oz. per additional foot.
 c) 1-1/8" = 0.8 oz. per additional foot.
 (6) For additional charging instructions please refer to the QRD.

ACCESSORIES - Condensing Unit

Start Assist Kit - 912933

Provides additional starting torque for the compressor motor when operating with low line voltage or high operating temperatures.

Extreme Wind Condition Mounting Kit - 1017210

Low Ambient Kit - 918837

COPPER WIRE SIZE — AWG (1% Voltage Drop)				
Supply Wire Length-Feet				Supply Circuit
200	150	100	50	Ampacity
6	8	10	14	15
4	6	8	12	20
4	6	8	10	25
4	4	6	10	30
3	4	6	8	35
3	4	6	8	40
2	3	4	6	45
2	3	4	6	50

Wire Size based on N.E.C. for 60° type copper conductors.

PANEL REMOVAL AND REPLACEMENT INSTRUCTIONS

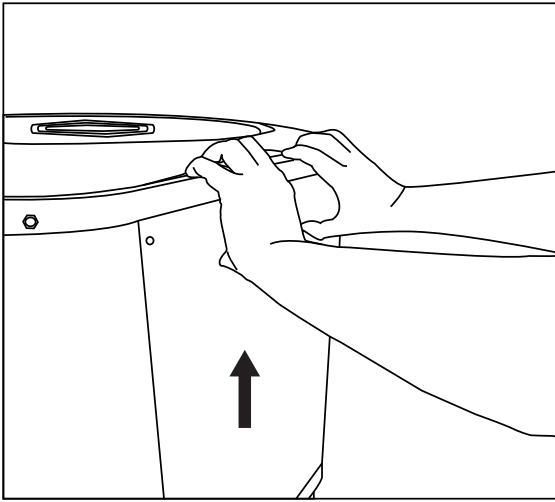

Removing Panels:

1. Remove screws.
2. Pull up on panel.
3. Rotate bottom of panel out.
4. Pull panel off.

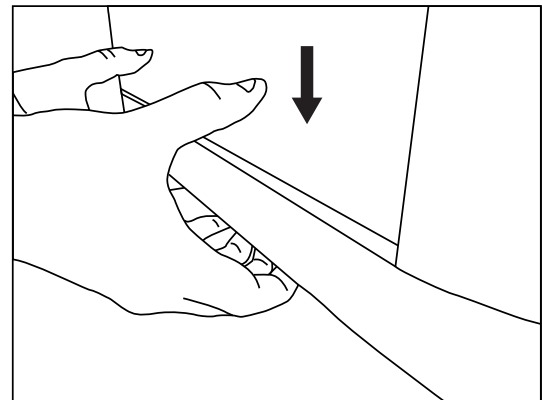
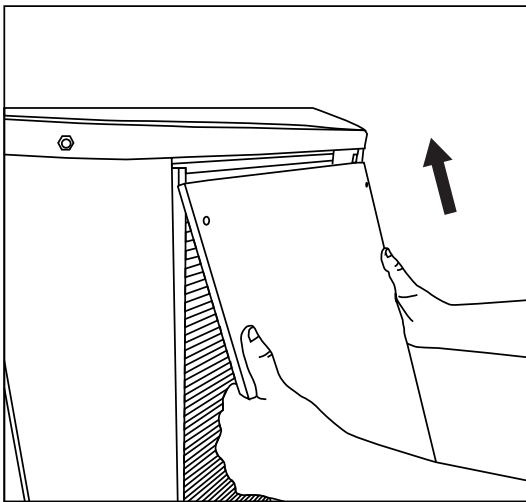
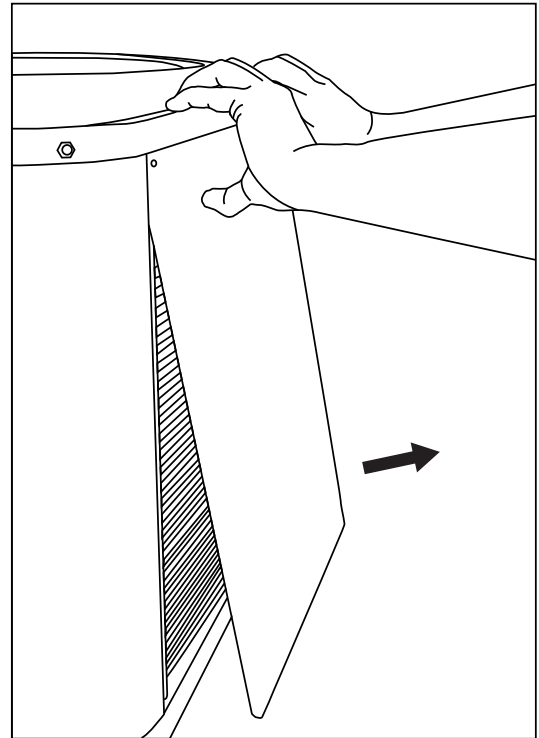

Reinstalling Panels:

1. Place panel back in towards top of unit.
2. Rotate bottom of panel inwards.
3. Push panel down until it fills gap at bottom of unit.
4. Replace screws.

SYSTEM COOLING CAPACITIES

16 SEER — Extra High Efficiency — Single Phase

Outdoor Unit	Indoor Unit	BTUH	SEER	EER	Low Speed SCFM	High Speed SCFM
FSA1BF4M2SN24K	C7B(A,H)MX24(C,U)-B + MB7VM(*)B	24,000	16	13	600	870
FSA1BF4M2SN36K	C7B(A,H)MX36(C,U)-B + MB7VM(*)B	35,000	16	12.5	810	1170
FSA1BF4M2SN48K	C7B(A,H)MX48(C,U)-C + MB7VM(*)C	46,500	16	12.5	990	1400
FSA1BF4M2SN60K	C7B(A,H)MX60(C,U)-C + MB7VM(*)C	56,000	16	12.5	1200	1700

Outdoor Unit	Indoor Unit	BTUH	SEER	EER	Low Speed SCFM	High Speed SCFM
FSA1BF4M2SN24K	B6VMMX24K-B	24,000	16	13	600	870
FSA1BF4M2SN36K	B6VMMX36K-B	35,000	16 <td 12.5	810	1170	
FSA1BF4M2SN48K	B6VMMX48K-C	46,500	16	12.5	990	1400
FSA1BF4M2SN60K	B6VMMX60K-C	56,000	16	12.5	1200	1700

Air handlers and coils used in tables are designed and manufactured by Nortek Global HVAC, LLC.

See current AHRI Directory for certified combinations and ratings.

www.ahridirectory.org

CORESENSE™ DIAGNOSTIC MODULE

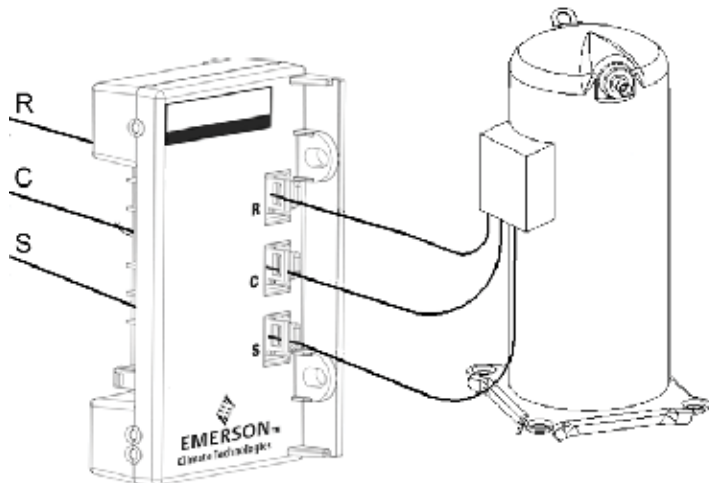

Figure 1
Wires Pulled Through Module

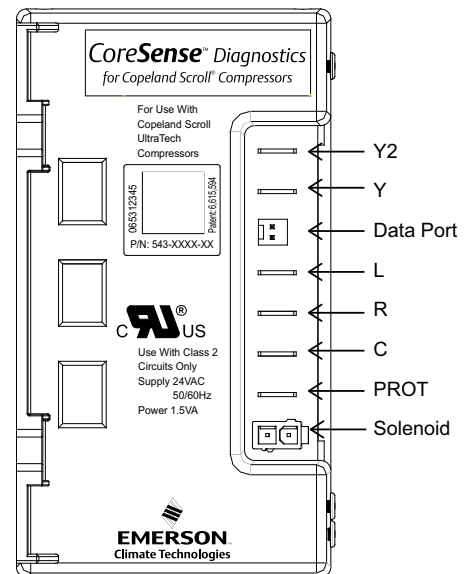

Figure 2
Terminal Locations

CORESENSE™ DIAGNOSTIC MODULE (CONT.)

CoreSense™ Flash Code Description			
Alert Code	Alert Condition	Lockout Level	Lockout Indication
Normal Run Solid Green	Normal operation, no trip.	N/A	N/A
Code1 Yellow Flash 1	Long run time. Compressor is running for more than 18 hours at full load. (Code1 is disabled in Heat Pump mode.)	N/A	N/A
Code2 Yellow Flash 2	Compressor Pressure trip. Compressor runs for 12sec to 15min followed by a compressor trip condition lasting longer than 7min.	4x consecutive, 10x total	Red: Flash 2
Code 3 Yellow Flash 3	Pressure switch cycling. Compressor runs for 12sec to 15min followed by a compressor trip lasting between 35sec to 7min.	4x consecutive, 10 total	Red: Flash 3
Code4 Yellow Flash 4	Locked rotor. Compressor trips within a compressor run time of 12sec and does not start within 35sec.	10x consecutive	Red: Flash 4
Code5 Yellow Flash 5	Compressor moderate run trip. Compressor runs for 15min to 18hrs followed by a compressor trip lasting longer than 7min.	4x consecutive, 10x total	Red: Flash 5
Code6 Red Flash 6	Open start circuit. Module has detected Y or Y1, and current in the R winding of the compressor and no current in the S winding of the compressor for 2 seconds.	1 occurrence	Red: Flash 6
Code7 Red Flash 7	Open run circuit. Module has detected Y or Y1, and current in the S winding of the compressor and no current in the R winding of the compressor for 2 seconds.	1 occurrence	Red: Flash 7
Code8 Yellow Flash 8	Welded Contactor. Module has detected line currents in R and S windings, and Y or Y1 is at 0 VAC for 15 seconds.	N/A	N/A
Code9 Yellow Flash 9	Low Voltage. Module has detected a 24 VAC supply voltage below 17 VAC +/- 1 VAC for 2 seconds	N/A	N/A
Code10 Red Flash 10	Over Current Protection. PROT terminal has above a 2A input for more than 40 milliseconds.	1 occurrence	Red: Flash 10



GENERAL TERMS OF LIMITED WARRANTY

Nortek Global HVAC, LLC will furnish a replacement for any part of this product which fails in normal use and service within the terms and conditions of the warranty.

For complete details of the Limited Warranty, including applicable terms and conditions, see your local installer or contact the Nortek Global HVAC, LLC warranty department for a copy.

Before purchasing this appliance, read important energy cost and efficiency information available from your retailer. Specifications and illustrations subject to change without notice and without incurring obligations. Printed in U.S.A (04/2017)