



## User's Information Manual

# PRESTIGE



Solo PA 80, 110, 155, 175, 250, 299, 399

Excellence 110



### NOTICE

- Customer must register unit within thirty (30) days of installation in order to gain warranty coverage. See Warranty Card for details.
- Leave all documentation received with appliance with the owner for future reference.

### **WARNING**

- To maintain the safety & longevity of your appliance, read and follow the maintenance schedule information throughout this manual.
- If the information in this manual is not followed exactly, a fire or explosion may result causing substantial property damage, serious injury, or death.

#### FOR YOUR SAFETY

- Do not store or use gasoline or other flammable vapors and liquids in the vicinity of this or any other appliance.
- **WHAT TO DO IF YOU SMELL GAS**
  - Do not try to light any appliance
  - Do not touch any electrical switch; do not use any phone in your building.
  - Immediately call your gas supplier from a neighbor's phone. Follow the gas supplier's instructions.
  - If you cannot reach your gas supplier, call the fire department.

Installation and service must be performed by a qualified installer, service agency or the gas supplier.

**INTENTIONALLY LEFT BLANK**

# TABLE OF CONTENTS

---

<b>PRODUCT AND SAFETY INFORMATION.....</b>	<b>V</b>
<b>CHAPTER 1 - COMBUSTION AIR CONTAMINATION.....</b>	<b>1</b>
<b>CHAPTER 2 - MAINTENANCE SCHEDULES .....</b>	<b>3</b>
2.1. Service Technician .....	3
2.2. Owner Maintenance.....	3
<b>CHAPTER 3 - MAINTENANCE PROCEDURES .....</b>	<b>5</b>
3.1. Owner Maintenance Procedures .....	5
3.2. Daily Maintenance.....	5
3.2.1 Check Surrounding Area .....	5
3.2.2 Check Ventilation Air Openings.....	5
3.2.3 Check Temperature Display and Pressure Gauge .....	5
3.3. Monthly Maintenance .....	6
3.3.1 Check Vent and Combustion Air Piping .....	6
3.3.2 Check Pressure Relief Valve .....	6
3.3.3 Check Condensate Drain System .....	6
3.4. 6-Month Maintenance .....	7
3.4.1 Check Water and Gas Piping .....	7
3.4.2 Operate Pressure Relief Valve .....	7
3.4.3 Check Carbon Monoxide Detectors.....	7
<b>CHAPTER 4 - OPERATING INSTRUCTIONS .....</b>	<b>9</b>
<b>CHAPTER 5 - ACVMAX OPERATION .....</b>	<b>11</b>
5.1. ACVMax Navigation .....	11
5.2. ACVMax Menu Structure.....	12
5.3. Home Screen.....	13
5.4. Status Line Messages.....	14
5.5. Main Menu .....	15
5.6. EZ Setup .....	15
5.7. CH / DHW Operation .....	16
5.8. Language Selection .....	17
5.9. Boiler Information .....	18
5.9.1 Information Items.....	19
5.10. Lockout History .....	20
5.10.1 Lockout Screen.....	21
5.10.2 Manual Reset Lockouts.....	22
5.10.3 Automatic Reset Blocking Lockouts.....	23
<b>CHAPTER 6 - REPLACEMENT PARTS .....</b>	<b>25</b>

## INDEX OF ILLUSTRATIONS

---

Fig. 1 - Condensate Drain Assembly.....	6
Fig. 2 - ACVMax User Interface.....	11
Fig. 3 - PRESTIGE Solo 80/110 Jacket Components.....	25
Fig. 4 - PRESTIGE Solo 155/175/250 Jacket Components.....	26
Fig. 5 - PRESTIGE Solo 299/399 Jacket Components.....	27
Fig. 6 - PRESTIGE Excellence 110 Jacket Components.....	28
Fig. 7 - PRESTIGE Solo 80/110 Internal Components.....	29
Fig. 8 - PRESTIGE Solo 155/175/250 Internal Components.....	30
Fig. 9 - PRESTIGE Solo 299/399 (1) Internal Components.....	31
Fig. 10 - PRESTIGE Excellence 110 Internal Components.....	32
Fig. 11 - PRESTIGE Solo 80/110 / Excellence 110 Burner Components.....	33
Fig. 12 - PRESTIGE Solo 155/175/250 Burner Components.....	34
Fig. 13 - PRESTIGE Solo 299/399 (1) Burner Components.....	35
Fig. 14 - PRESTIGE Solo 299/399 (2) Burner Components.....	36
Fig. 15 - PRESTIGE Solo Control & Display Enclosures.....	37



## PRODUCT AND SAFETY INFORMATION

### IMPORTANT SAFETY INFORMATION FOR THE HOMEOWNER AND THE TECHNICIAN

This manual contains important information with respect to the operation and maintenance of the appliance.

This manual must be provided to the Homeowner, who will keep it in a safe place for future reference.

**Triangle Tube accepts no liability for any damage, injury, or loss of life resulting from incorrect installation, alteration of any factory supplied parts, or the use of parts or fittings not specified by Triangle Tube. If there is a conflict or doubt about the proper installation of the unit or any factory supplied replacement parts please contact Triangle Tube Technical Support.**

### DEFINITIONS

The following terms are used throughout this manual to bring attention to the presence of potential hazards or to important information concerning the product.

#### **DANGER**

Indicates the presence of a hazardous situation which, if ignored, will result in substantial property damage, serious injury, or death.

#### **WARNING**

Indicates a potentially hazardous situation which, if ignored, can result in substantial property damage, serious injury, or death.

#### **CAUTION**

Indicates a potentially hazardous situation which, if ignored, can result in minor property damage, or injury.

### **NOTICE**

*Indicates special instructions on installation, operation or maintenance, which are important to the equipment but not related to personal injury hazards.*

### **BEST PRACTICE**

*Indicates recommendations made by Triangle Tube for the installers, which will help to ensure optimum operation and longevity of the equipment.*

### **STOP!** **READ BEFORE SERVICING**

**Failure to adhere to the guidelines within this manual can result in substantial property damage, serious injury, or death.**

**TECHNICIAN:** When calling or writing about the PRESTIGE, please have the boiler model and serial number available.

#### **DANGER**

- Do not use this appliance if any part has been under water. Immediately call a qualified service technician to inspect the appliance and to replace any part of the control system which has been under water.
- Avoid electrical shock when servicing the appliance, by disconnecting the electrical supply prior to performing service or maintenance.
- Failure to comply with these instructions will result in substantial property damage, serious injury, or death.

#### **WARNING**

- The Prestige Installation manual is for use only by a qualified heating installer/service technician. The homeowner will use this User's Information Manual for reference.
- What to do if you smell gas:
  - Do not try to light any appliance
  - Do not touch any electrical switch; do not use any phone in your building.
  - Immediately call your gas supplier from a neighbor's phone. Follow the gas supplier's instructions.
  - If you cannot reach your gas supplier, call the fire department.
- Do not store or use gasoline or other flammable vapors and liquids in the vicinity of this or any other appliance.
- Prior to installing this product, the qualified installer must read all instructions included in this manual and all accompanying manuals/documents with this appliance.
- All installation steps required in these manuals must be performed in the proper order given.
- This product must be maintained / serviced and inspected annually by a qualified service technician.
- Failure to comply with these instructions can result in substantial property damage, serious injury, or death.

## PRODUCT AND SAFETY INFORMATION



- A byproduct of any gas fired appliance is carbon monoxide. Triangle Tube requires the installation of a minimum of two (2) hard-wired carbon monoxide detectors with an alarm and battery back-up; one in the mechanical room where the boiler is located and another installed in the living area outside the bedroom(s) for all installations. Consult the local authority having jurisdiction for any additional carbon monoxide detector requirements in your area. See *Chapter 2 of the Prestige Installation & Maintenance Manual* for additional carbon monoxide detector requirements in Massachusetts.
- Failure to comply with these instructions can result in substantial property damage, serious injury, or death.

### Service and Maintenance:

- Allow the unit to cool down prior to servicing to avoid severe burns.
- The PRESTIGE must be maintained as outlined in this manual and have at least annual service performed by a qualified service technician to ensure unit / system reliability.

### PRESTIGE Operation

- Do not block flow of combustion air to the PRESTIGE. If the combustion air blockage is easily accessible and removable, then remove it. If blockage is not obvious or cannot be removed, have the unit and system checked by a qualified service technician.
- Do not allow contaminated air to enter the unit's combustion air inlet. See page 3 for details.
- The PRESTIGE is equipped with a low water cutoff device. The boiler and system piping must be filled and pressurized to 12 psig prior to startup. The unit will shut down if the pressure falls below 7.2 psig.
- Should overheating occur or if the gas supply fails to shut off, DO NOT turn OFF or disconnect the electrical supply to the pump. Instead, turn OFF the manual gas control valve external to the appliance.

### Boiler and System Water

- Have the boiler and system water chemistry checked at least annually by a qualified service technician.
- Do not use petroleum-based cleaning or sealing compounds in the boiler or system. Gaskets and seals in the system may be damaged, which can result in substantial property damage.
- Do not use any product not specifically designed for boiler / hydronic heating systems. Serious damage to the unit, piping system, personnel and / or property may result.
- Continual fresh makeup water will reduce the life of the PRESTIGE. Addition of oxygen can cause internal corrosion in the system components. All leaks in the system must be repaired at once to prevent excessive makeup water.
- Do not add cold makeup water when the appliance is hot. Thermal shock can potentially cause cracks in the heat exchanger.
- Failure to comply with these instructions can result in substantial property damage, serious injury, or death.

### CAUTION

- It is prohibited to carry out any modifications to the appliance without prior written consent from Triangle Tube.
- Faulty parts must only be replaced by genuine Triangle Tube factory parts.
- Failure to comply with these instructions can result in minor property damage, or injury.

### NOTICE

- *The homeowner is only permitted to carry out the basic set-up operations (EZ Setup) after he has received all relevant instructions from the installer. Any other set-up must be carried out by a qualified installer.*
- *In case of any anomaly, please call your qualified service technician.*
- *Make sure to reference the unit's model number and serial number from the rating label when inquiring about service or troubleshooting.*
- *Triangle Tube reserves the right to change the technical characteristics, components and features of its products without prior notice. Check for an updated version of this manual at [www.triangletube.com](http://www.triangletube.com).*

## PRODUCT AND SAFETY INFORMATION

---

### PRODUCT EFFECTIVITY - PRESTIGE SOLO 299/399

#### NOTICE

*Following a configuration upgrade on the Prestige Solo 299 and 399 blower/Venturi/gas valve assembly, two different configurations now exist in the Prestige Solo 299/399 boilers. To reflect the differences, a code (see table below) is allocated to each configuration and displayed in the relevant locations in the manual.*

Effectivity code	P Solo 299	P Solo 399
❶ - up to S/N	PA116182	PA116693
❷ - from S/N	— (*)	PA124663

(\*) Unknown at the time of printing - therefore, for P299 boilers, all S/N higher than effectivity code ❶ are concerned.

**INTENTIONALLY LEFT BLANK**

### **WARNING**

If the PRESTIGE combustion air inlet is located in an area likely to cause or contain contamination, or if products which could contaminate the air cannot be removed, the combustion air must be repiped and terminated at another location. Contaminated combustion air will damage the unit and its burner system, and can result in substantial property damage, serious injury, or death.

### **DANGER**

- Do not operate the PRESTIGE if the combustion air inlet is located near a laundry room or pool facility. These areas will always contain hazardous contaminants.
- Pool, laundry, common household, and hobby products often contain fluorine or chlorine compounds. When these chemicals pass through the burner and vent system, they can form strong acids. These acids will corrode the heat exchanger, burner components, and vent system, causing serious damage and possible flue gas spillage or water leakage into the surrounding area.
- Please read the information listed below. If contaminating chemicals are located near the area of the combustion air inlet, the installer must pipe the combustion air inlet to an area free of these chemicals.
- Failure to comply with these instructions will result in substantial property damage, serious injury, or death

### Potential contaminating products

- Spray cans containing chloro/fluorocarbons
- Permanent Wave Solutions
- Chlorinated wax
- Chlorine based swimming pool chemicals / cleaners
- Calcium Chloride used for thawing ice
- Sodium Chloride used for water softening
- Refrigerant leaks
- Paint or varnish removers
- Hydrochloric acid / muriatic acid
- Cements and glues
- Antistatic fabric softeners used in clothes dryers
- Chlorine-type bleaches, detergents, and cleaning solvents found in household laundry rooms
- Adhesives used to fasten building products and other similar products

### Areas likely to contain these products

- Dry cleaning / laundry areas and establishments
- Beauty salons
- Metal fabrication shops
- Swimming pools and health spas
- Refrigeration Repair shops
- Photo processing plants
- Auto body shops
- Plastic manufacturing plants
- Furniture refinishing areas and establishments
- New building construction
- Remodeling areas
- Garages with workshops

**INTENTIONALLY LEFT BLANK**

### 2.1. Service Technician

At least on an **annual** basis the following maintenance should be performed by a qualified service technician:

#### General

- Attend to any reported problems.
- Inspect the interior of the boiler jacket area; clean and vacuum if necessary.
- Clean the condensate drain assembly and fill with fresh water.
- Check boiler fluid pH on systems.
- Check for leaks, both inside and outside the unit: water, gas, flue and condensate.
- Verify vent piping and air inlet piping are in good condition, sealed tight and properly supported.
- Check boiler water pressure, piping and expansion tank.
- Check control settings.
- Check ignition electrode (sand off any white oxide; clean and reposition).
- Check ignition wiring and ground wiring.
- Check all control wiring and connections.
- Check burner flame pattern (stable and uniform).
- Check carbon monoxide detectors.

#### Additional items if combustion or performance is poor:

- Clean heat exchanger and flue ways.
- Remove burner assembly and clean burner head using compressed air only.

Service Technician maintenance procedures can be found in Chapter 17 of the Prestige Installation and Maintenance manual.

Once the maintenance items are completed, review the service with the owner.

### 2.2. Owner Maintenance

#### Periodically:

- Check the area around the unit.
- Check and remove any blockage from the combustion air inlet and ventilation openings.
- Check the temperature and pressure gauges.

#### Monthly:

- Check vent piping.
- Check combustion air inlet piping.
- Check the pressure relief valve.
- Check the condensate drain system.

#### Every 6 months:

- Check boiler piping and gas supply piping for corrosion or potential signs of leakage.
- Operate the pressure relief valve.
- Check carbon monoxide detectors.



**Follow the maintenance procedures given in Chapter 3 on page 5 of this manual. Failure to perform the service and maintenance or follow the directions in this manual can result in damage to the PRESTIGE or system components, resulting in substantial property damage, serious injury, or death.**

**INTENTIONALLY LEFT BLANK**



### 3.1. Owner Maintenance Procedures



The PRESTIGE must be inspected and serviced annually, preferably at the start of the heating season, by a qualified service technician. In addition, the owner maintenance and care of the unit as outlined in *Chapter 2 on page 3* and further explained in this chapter should be performed to assure maximum efficiency and reliability of the unit. Failure to service and maintain the PRESTIGE and the system components can result in equipment failure, resulting in substantial property damage, serious injury, or death.

#### NOTICE

*The following information provides detailed instructions for completing the owner maintenance items outlined in the maintenance schedule in Chapter 2 on page 3.*

### 3.2. Daily Maintenance

#### 3.2.1 Check Surrounding Area



Eliminate all the materials listed in *Chapter 1 on page 1* from the area surrounding the unit and from the vicinity of the combustion air inlet.

If contaminants are found:

- Remove products immediately from the area. If they have been there for an extended period, call a qualified service technician to inspect the unit for possible damage from corrosion.
- If products cannot be removed, immediately call a qualified service technician to re-pipe the combustion air inlet piping and locate the combustion air intake away from the contaminated areas.

Failure to comply with these instructions can result in substantial property damage, serious injury, or death

- Verify that the area surrounding the PRESTIGE is free of combustible / flammable materials or flammable vapors or liquids. Remove immediately if found.
- Verify that combustion air inlet area is free of any contaminants. Refer to the materials listed in *Chapter 1 on page 1* of this manual. If any of these products are in the area from which the unit takes its combustion air, they must be removed immediately or the combustion air intake must be relocated to another area.

#### 3.2.2 Check Ventilation Air Openings

- Verify that all ventilation openings to the mechanical room or building are open and unobstructed.
- Check and verify that the vent termination and the combustion air intake are free of debris and obstructions. Remove any debris on the air intake or flue exhaust openings. If removing the debris does not allow the unit to operate correctly, contact a qualified service technician to inspect the unit and the vent / combustion air system.

#### 3.2.3 Check Temperature Display and Pressure Gauge

- Ensure the pressure reading on the pressure gauge does not exceed 25 psig. Higher pressure readings may indicate a problem with the expansion tank.
- Ensure the temperature on the display panel does not exceed 194°F. Higher temperature readings may indicate a water flow problem.
- Contact a qualified service technician if problem persists.

### 3.3. Monthly Maintenance

#### 3.3.1 Check Vent and Combustion Air Piping

- Visually inspect the venting system and combustion air piping for blockage, deterioration of gaskets or leakage. Contact a qualified service technician immediately if any problems are found.



**Failure to inspect the vent system and combustion air inlet piping and to have any conditions repaired, will result in serious injury, or death.**

#### 3.3.2 Check Pressure Relief Valve

1. Visually inspect the pressure relief valve and the relief valve discharge pipe for signs of weeping or leakage.
2. If the pressure relief valve weeps often, the expansion tank may not be operating properly. Immediately contact a qualified service technician to inspect the unit and system.

#### 3.3.3 Check Condensate Drain System

1. Ensure condensate drain assembly is firmly secured to bottom of the unit. See *Fig. 1 on the right*.



**Do not operate the boiler without the factory-supplied condensate drain assembly installed. Operation of the boiler without the condensate drain assembly installed can result in property damage, serious injury, or death.**

2. While the unit is running, check the discharge end of the condensate drain tubing. Ensure no flue gas is leaking from the condensate drain tubing by holding your fingers near the opening.
3. If you notice flue gas leaking, turn off the unit and contact a qualified service technician to inspect the unit and condensate drain assembly.

4. Ensure the condensate drain tubing is not blocked by pouring water through the fill plug port on the condensate drain assembly. The water should flow out of the end of the drain tubing. If water does not appear at the end of the drain tubing, contact a qualified service technician to inspect and clean the condensate drain assembly.
5. To fill the condensate drain assembly, remove the fill plug from the condensate assembly. Slowly pour water into the assembly until water appears at the end of the drain tubing. Stop filling and replace plug.

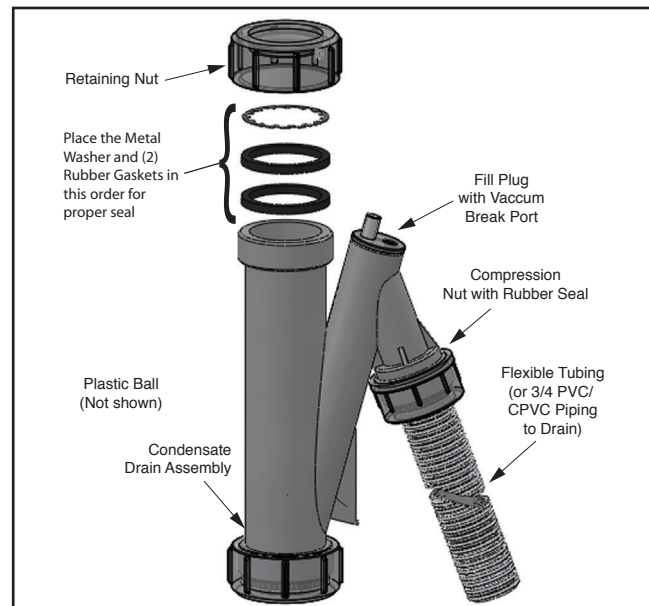

*Fig. 1 - Condensate Drain Assembly*

### 3.4. 6-Month Maintenance

#### 3.4.1 Check Water and Gas Piping

1. Remove the boiler front jacket panel and perform a gas leak inspection per steps 1 through 6 of the Operating Instructions on page 9. If gas odor or a leak is detected, immediately shut down the unit following procedures on page 9. Call a qualified service technician.
2. Visually inspect for leaks around the internal boiler water connections and around the heat exchanger. Visually inspect the external system piping, circulators, and system components and fittings. Immediately call a qualified service technician to repair any leaks.



**Have leaks fixed at once by a qualified service technician. Failure to comply can result in substantial property damage, serious injury, or death.**

#### 3.4.2 Operate Pressure Relief Valve

1. Before proceeding, verify that the relief valve outlet has been piped to a safe place, avoiding any possibility of scalding from hot water.



**To avoid water damage or scalding, a discharge line must be connected to the relief valve outlet and directed to a safe place of disposal. This discharge line must be installed by a qualified service technician in accordance with the PRESTIGE installation manual. The discharge line must be terminated so as to eliminate possibility of severe burns or property damage should the valve discharge. Failure to comply can result in substantial property damage, serious injury, or death.**

2. Read the pressure gauge to ensure the system is pressurized. Lift the relief valve top lever slightly, allowing water to relieve through the valve and discharge piping.

3. If water flows freely, release the lever and allow the valve to seat. Watch the end of the relief valve discharge pipe to ensure that the valve does not weep after the line has had time to drain. If the valve weeps, lift the lever again to clean the valve seat. If the valve does not properly seat and continues to weep afterwards, contact a qualified service technician to inspect the valve.
4. If water does not flow from the valve when you lift the lever completely, the valve or discharge line may be blocked. Immediately shut the unit down per the instructions on page 9. Call a qualified service technician to inspect the valve and discharge line.

#### 3.4.3 Check Carbon Monoxide Detectors

Verify that at least two (2) carbon monoxide detectors are installed and operating properly. One must be installed in the mechanical room where the PRESTIGE is located and another installed in the living area outside the bedroom(s).

Contact a qualified service technician if carbon monoxide detectors are not installed or operating properly.

**INTENTIONALLY LEFT BLANK**

## FOR YOUR SAFETY, READ BEFORE LIGHTING





**If you do not follow these instructions exactly, a fire or explosion may result, causing substantial property damage, serious injury, or death.**

- A. This appliance does not have a pilot. It is equipped with an ignition device which automatically lights the burner. DO NOT try to light the burner by hand.
- B. BEFORE OPERATING, smell all around the appliance area for gas. Be sure to smell next to the floor because some gas is heavier than air and will settle on the floor.
- C. Use only your hand to turn the external manual gas valve. Never use tools. If the valve will not turn by hand, don't try to repair it; call a qualified service technician. Force or attempted repair may result in a fire or explosion.
- D. Do not use this appliance if any part has been under water. Immediately call a qualified service technician to inspect the appliance and to replace any part of the control system and any gas control which has been under water.

### WHAT TO DO IF YOU SMELL GAS

- Do not try to light any appliance.
- Do not touch any electric switch; do not use any phone in your building
- Immediately call your gas supplier from a neighbor's phone. Follow the gas supplier's instructions.
- If you cannot reach your gas supplier, call the fire department.

## OPERATING INSTRUCTIONS

1. **STOP!** Read the safety information above. This appliance is equipped with an ignition device which automatically lights the burner. DO NOT try to light the burner by hand.
2. Set room thermostat(s) to lowest setting. Turn the external manual gas valve handle clockwise  to "CLOSE" (valve handle must be perpendicular to gas piping).
3. Turn the service switch on the appliance control panel OFF.
4. Remove the front jacket panel on the unit.
5. Wait five (5) minutes to clear out any gas. If you then smell gas in the jacket enclosure or around the unit, STOP! Follow "B" in the safety information above. If you don't smell gas, go to the next step.
6. Turn the external manual gas valve handle counter clockwise  to "OPEN" gas supply (valve handle shall be parallel to gas piping).
7. Turn the service switch on the appliance control panel "ON".
8. Set room thermostat(s) to desired setting(s).
9. The appliance control panel display will show the current operating status on the Status Line at the bottom of the screen. "Standby" means there is no call for heat (all thermostats are satisfied). "CH Demand" indicates a space heating call has been received. "DHW Demand" indicates a domestic hot water call has been received. A flame icon will be displayed when the unit is fired.
10. If the unit will not operate, follow the instructions "To Turn Off Gas to Appliance" and call your service technician or gas supplier.
11. Replace the front jacket panel. Make sure the panel is seated firmly in place and all mounting screws are tightened.

## TO TURN OFF GAS TO APPLIANCE

1. Set the room thermostat to lowest setting.
2. Turn the service switch on the appliance control panel to "OFF"
3. Turn the external manual gas valve handle clockwise  to "CLOSE".

**INTENTIONALLY LEFT BLANK**

The ACVMax Boiler Management System is designed to be flexible yet easy to use. ACVMax monitors and controls the PRESTIGE to provide heat as efficiently as possible.

All ACVMax features are easy to use through a graphical display where information is presented either graphically or in plain English, so code charts are not required.

**Fig. 2 below** shows an ACVMax display example of the PRESTIGE Solo fired for a domestic hot water demand.



### 5.1. ACVMax Navigation

Navigation is performed through four arrow buttons **UP, DOWN, LEFT, RIGHT** with a center **OK** button for making selections and entering information.

The **INSTALLER** button (the small round button) provides the installing contractor with full access to all available features after entering a password.

The Main Menu can be entered from the Home Screen by pressing the **OK** button.

The menu system utilizes icons to represent each selection. The current selected menu is displayed as a reversed image with a text description shown at the top of the display. Menus can be entered by highlighting the desired icon and pressing the **OK** button.

The Home Screen icon  at the bottom of each screen returns to the Home Screen when selected. The Previous Screen icon  at the bottom of each screen returns to the previous screen when selected.

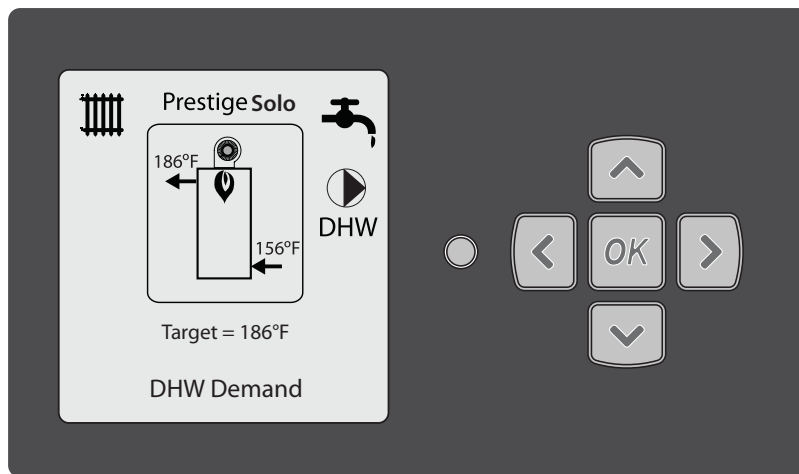
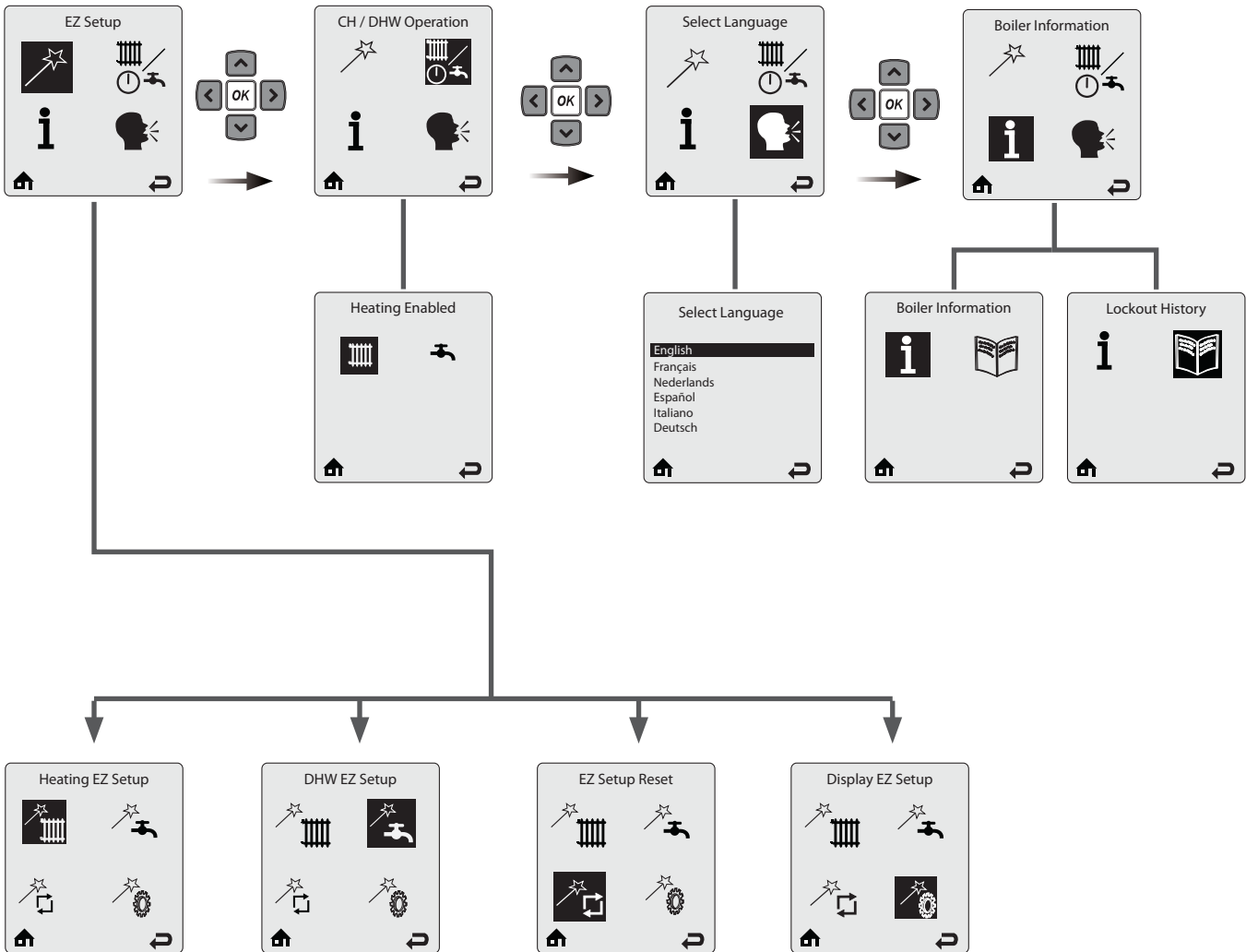
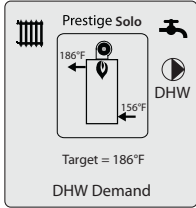

Fig. 2 - ACVMax User Interface

# CHAPTER 5 - ACVMAX OPERATION

## 5.2. ACVMax Menu Structure

### Home Screen



CHAPTER 5













## CHAPTER 5 - ACVMAX OPERATION

### 5.3. Home Screen

The Home Screen presents status information in a very user friendly way so that the current state of the boiler can be quickly accessed.

- **Screen backlight** - it will illuminate when any button is depressed, and remain illuminated for five minutes.
- **Screen contrast** - it can be adjusted at the Home screen by pressing and holding the **OK** button, then pressing and holding the **LEFT** button along with the **OK** button. Press the **UP** and **DOWN** button to increase or decrease the contrast while holding the **OK** and **LEFT** buttons depressed. All buttons must be released and the procedure performed again to switch between increasing and decreasing contrast.

### Main Icons of ACVMAX display

-  **Central Heating** - indicates information related to central/space heating.
-  **DHW** - indicates information related to Domestic Hot Water.
-  **Home** - to go back to the home screen.
-  **Back** - to go back to the previous screen.
-  **Warm Weather Shutdown** - displays on the home screen when the outdoor temperature reaches the Warm Weather Shutdown temperature.
-  **Reset** - to reset the system to the factory settings.
-  **Settings** - to access controller settings (language, units, etc.).
-  **Easy Setup** - to quickly adjust the most common settings.
-  **CH/DHW operation** - to enable/disable the central/space heating or Domestic Hot Water functions
-  **Information** - to get information on the boiler.

The model is indicated at the top of the screen.

The PRESTIGE Solo is represented in the center of the Home Screen. Basic operating information such as supply and return temperatures are displayed as well as current burner status.

**Radiator icon:** indicates that a central heating call has been received. A small number 1 or 2 indicates which CH calls are active

A **flame symbol** is displayed when the unit is fired. The flame size changes to indicate the current firing rate.

**Basic information:** The user can toggle through items using the LEFT and RIGHT keys to view Target, Supply, Return, Domestic, Outdoor, System and Mix Zone temperatures.

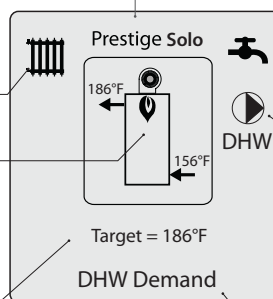

**Faucet icon:** indicates that a DHW call has been received.

**Circulator icons:** indicate which circulators are currently powered.

**Status line:** displays the current operating state of the boiler. See paragraph 5.4 on page 14.

## CHAPTER 5 - ACVMAX OPERATION

### 5.4. Status Line Messages

**Standby** - Indicates that the Prestige is ready to respond when a demand is received.

**CH Demand** - A central heating call has been received.

**DHW Demand** - A domestic hot water call has been received.

**CH/DHW Demand** - Central heating and domestic hot water calls are being received simultaneously. Both calls are being satisfied simultaneously because domestic hot water priority has been disabled.

**DHW Priority** - Central heating and domestic hot water calls are being received simultaneously. Domestic hot water call is being satisfied first because it has priority over central heating calls.

**Priority Timeout** - Central heating and domestic hot water calls are being received simultaneously. The domestic hot water priority time limit has been exceeded. Priority will now switch back and forth between central heating and domestic hot water calls until one call is satisfied.

**External Demand** - An external modulation call has been received.

**Slave Operation** - The Prestige is a slave in a cascade system.

**Manual Operation** - The burner or circulators have manually been enabled in the Installer Menu.

**CH Burner Delay** - The burner will not fire until the call blocking time has elapsed.

**DHW Burner Delay** - The burner will not fire until the call blocking time has elapsed.

**CH Setpoint Reached** - The burner is not fired because the supply/system water temperature exceeds the setpoint. The central heating circulator(s) continue(s) to operate and the burner will fire again once the supply/system water temperature drops below the setpoint.

**DHW Setpoint Reached** - The burner is not fired because the supply/system water temperature exceeds the setpoint. The domestic circulator(s) continue(s) to operate and the burner will fire again once the supply/system water temperature drops below the setpoint.

**CH Post Pump** - The central heating circulator(s) is/are running to remove heat from the Prestige at the completion of a call.

**DHW Post Pump** - The domestic hot water circulator(s) is/are running to remove heat from the Prestige at the completion of a call.

**Freeze Protection** - The burner is fired because the freeze protection feature has been activated. Freeze protection will end once the supply/system water temperature is raised to 60°F [16°C].

**Boiler Protection** - The burner firing rate is being reduced because of an excessive difference between the boiler supply and return temperatures. The firing rate will begin increasing once the temperature difference is less than 45°F [25°C].

**Low Water Pressure** - The system pressure has dropped to 10.1 psi. The Prestige will still respond to calls until the pressure drops below 7.2 psi. Increase system pressure to 14.5 psi to clear Low Water Pressure warning.

**Lockout Description** - The lockout which currently has the Prestige shut down is displayed.

# CHAPTER 5 - ACVMAX OPERATION

## 5.5. Main Menu

The Main Menu can be entered from the Home Screen by pressing the **OK** button.

The menu system utilizes icons to represent each selection. The currently selected menu is displayed as an inverted image with a text description shown at the top of the display.

Menus can be entered by highlighting the desired icon and pressing the **OK** button.

## 5.6. EZ Setup

The EZ Setup menus provide a simple way to quickly customize ACVMax for each installation. EZ Setup prompts the user to make selections which allows the PRESTIGE to be setup very quickly without searching through long lists of settings and manually making adjustments.

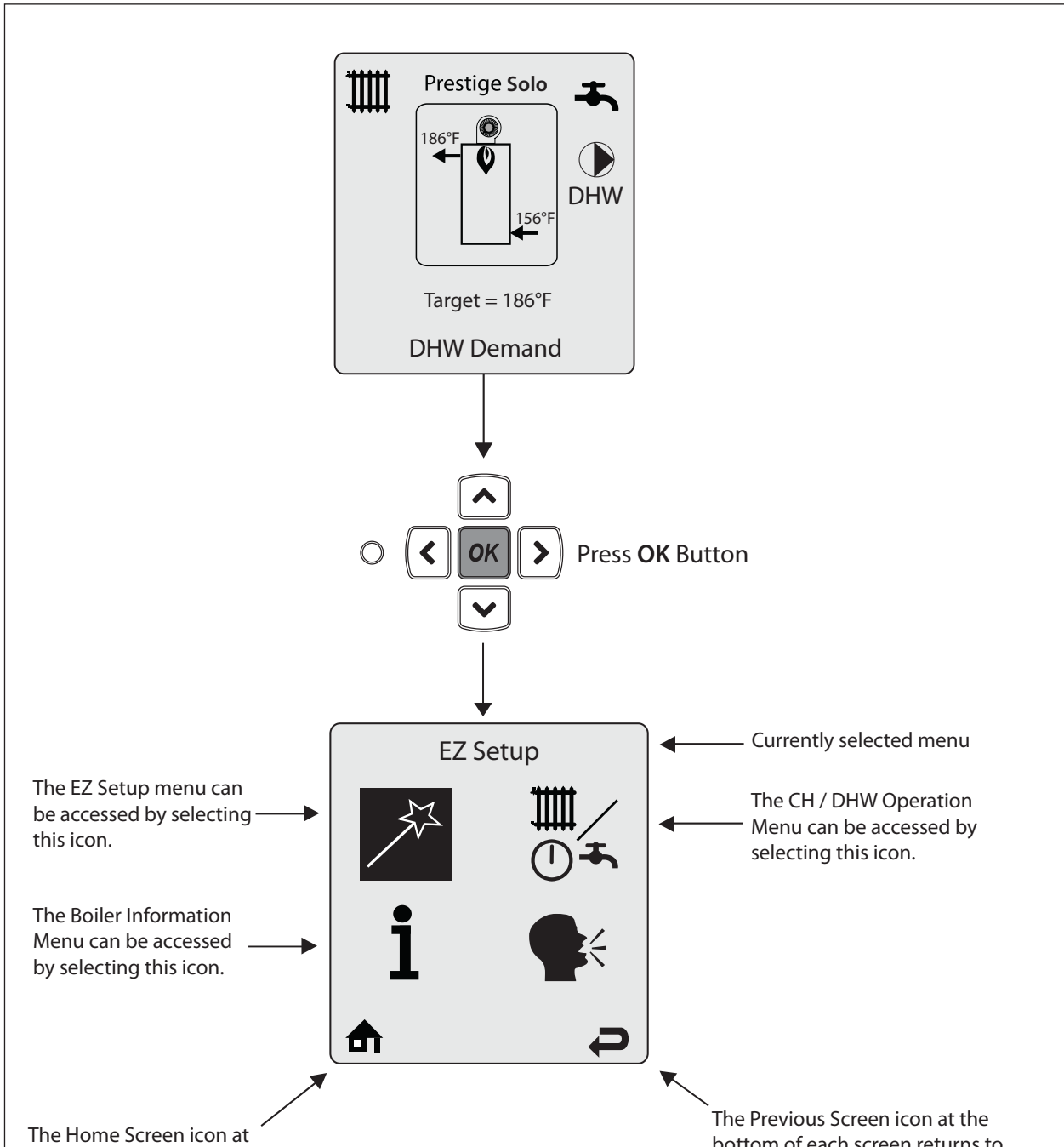

### 5.7. CH / DHW Operation

The CH / DHW Operation Menu can be entered from the Main Menu by selecting the CH / DHW Operation icon and pressing the **OK** button. The CH / DHW Operation Menu provides a simple way to disable either the central heating or domestic hot water functions of the Prestige.

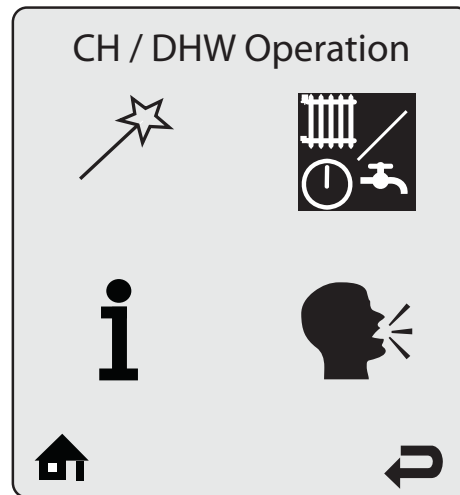

Heating Operation can be enabled and disabled by selecting the radiator icon and pressing the **OK** button to toggle operation between enabled and disabled.

A radiator icon with an X through it indicates that the heating function is disabled.

This icon is also displayed on the Home Screen when disabled.

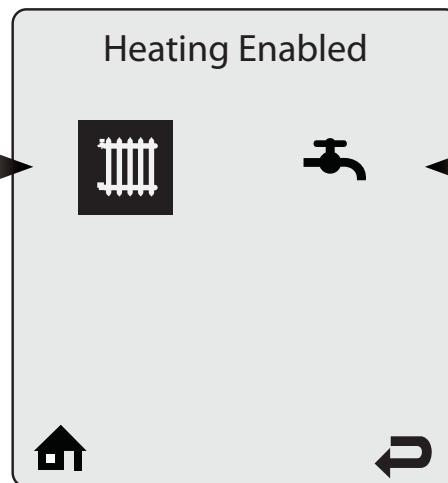

Domestic Hot Water Operation can be enabled and disabled by selecting the faucet icon and pressing the **OK** button to toggle operation between enabled and disabled.

A faucet icon with an X through it indicates that the domestic hot water function is disabled.

This icon is also displayed on the Home Screen when disabled.

### 5.8. Language Selection

The Select Language Menu can be entered from the Main Menu by selecting the Select Language icon and pressing the **OK** button. The Select Language Menu provides a simple way to select the language used on the display (nine different languages: English, French, Dutch, Spanish, Italian, German, Czech, Polish and Russian).

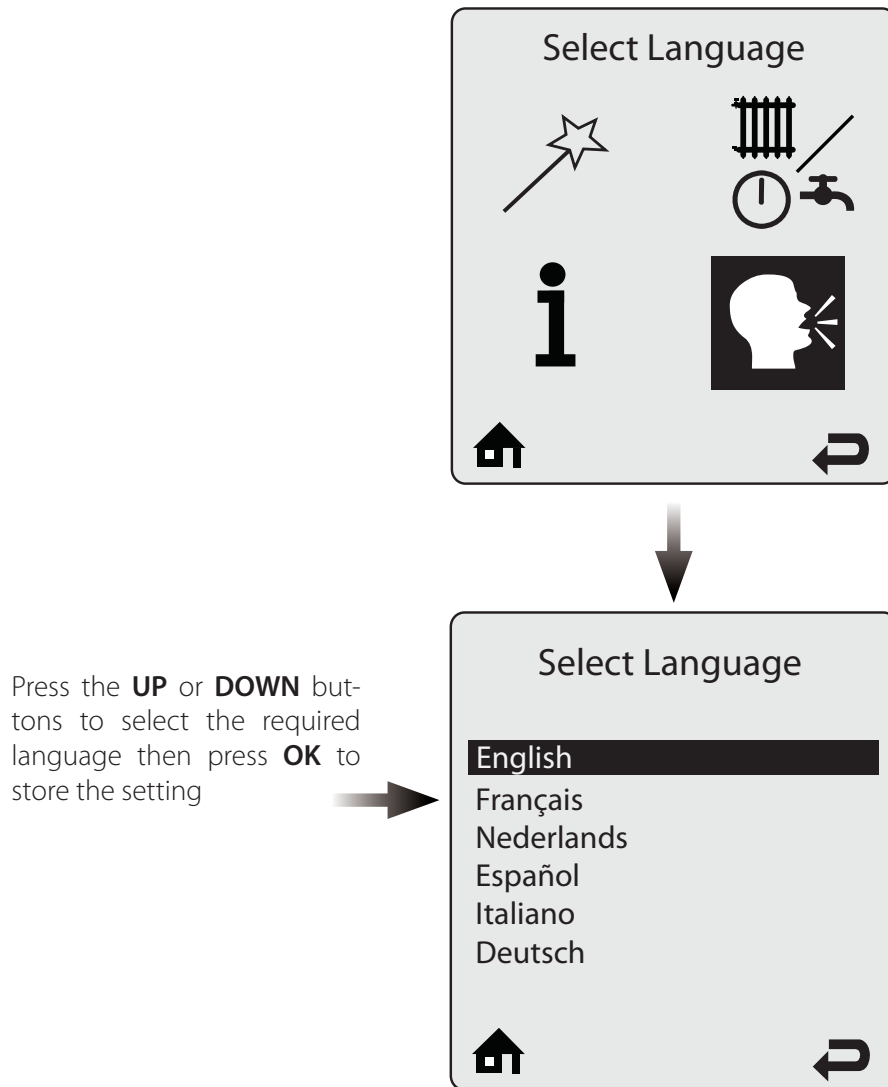

5.9. Boiler Information

Boiler Information can be viewed by selecting the Boiler Information icon and pressing the **OK** button. Boiler Information provides real time operating information of the Prestige.

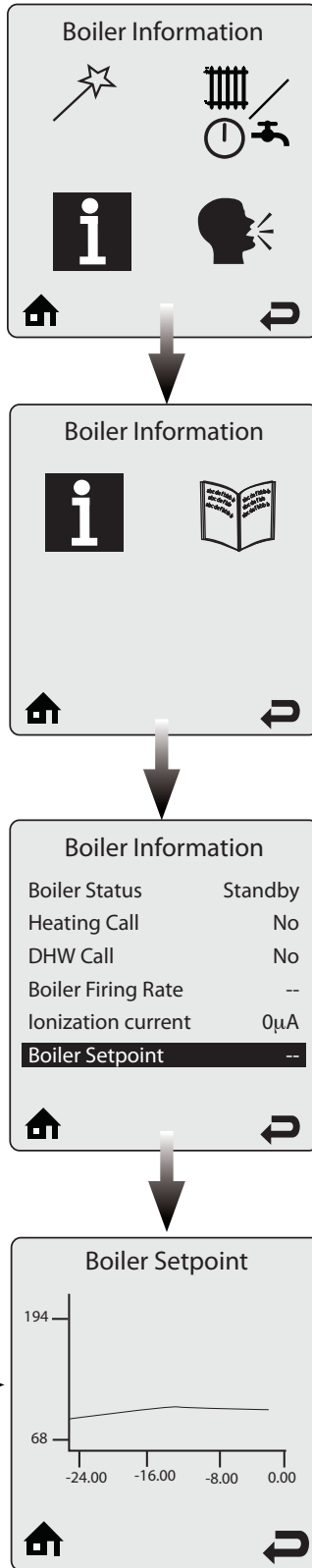

Boiler Information displays six boiler readings at a time. Each line contains an information item followed by its current value. Press the **UP** or **DOWN** buttons to scroll through additional information items.

Some information items include a logging function. Select the information item then press the **OK** button to view its graph. One sample is recorded every 12 minutes to produce a graph of the last 24 hours.

The following items have a logging function:

- Boiler Firing Rate
- Ionization Current
- Boiler Setpoint
- Boiler Supply Temperature
- Boiler Return Temperature
- Boiler Flue Temperature
- Outdoor Temperature
- DHW Storage Temperature
- External Modulation Signal Pressure

## CHAPTER 5 - ACVMAX OPERATION

### 5.9.1 Information Items

Information Item	Description
Boiler Status	Displays the current operating state of the Prestige. This is the same as the status line on the home screen.
Heating Call	Displays if a central heating call is present.
DHW Call	Displays if a domestic hot water call is present.
Boiler Firing Rate	Displays the current firing rate of the Prestige.
Ionization Current	Displays the current flame ionization current from the ignitor.
Boiler Setpoint	Displays the current setpoint of the Prestige.
Supply Temp.	Displays the current supply temperature of the Prestige.
Return Temp.	Displays the current return temperature to the Prestige.
Boiler Flue Temp.	Displays the current flue temperature of the Prestige.
Outdoor Temp.	Displays the current outdoor temperature.
DHW Storage Temp.	Displays the current DHW storage temperature when Indirect Water Heater Sensor PSRKIT22 is installed.
External Modulation Signal	Displays the current external modulation signal being received from an external controller.
Pressure	Displays the current system water pressure.
CH Ignitions	Displays the number of central heating ignitions since the unit was installed. This counter increases in increments of twenty.
CH Runtime	Displays the number of hours the Prestige has run for a central heating call since the unit was installed.
DHW Ignitions	Displays the number of domestic hot water ignitions since the unit was installed. This counter increases in increments of twenty.
DHW Runtime	Displays the number of hours the Prestige has run for a domestic hot water call since the unit was installed.
Mix Zone Temperature	Displays the current low temperature mix zone temperature.

5.10. Lockout History

Lockout History can be viewed by selecting the Lockout History icon and pressing the **OK** button. The Lockout History Screen lists the last eight lockouts along with how long ago they occurred.

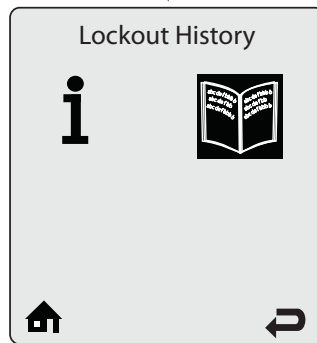
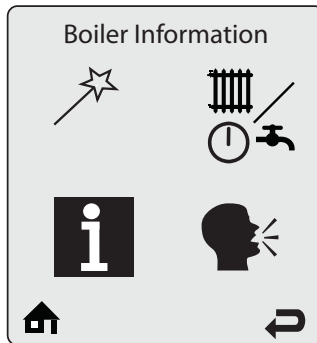

Lockout History displays the last eight lockouts. The newest lockout is displayed at the top of the screen.

The lockout message is followed by how long ago the error occurred.

Press the **UP** or **DOWN** buttons to scroll through additional lockouts.

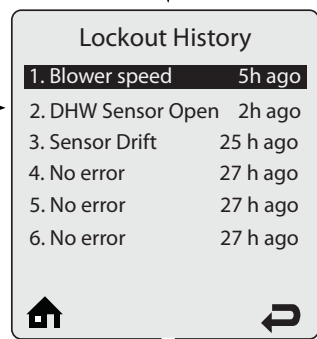

Lockout Details displays the lockout at the top of the screen followed by a snapshot of the boiler information recorded at the time of the lockout.

Press the **UP** or **DOWN** buttons to scroll through additional information items.

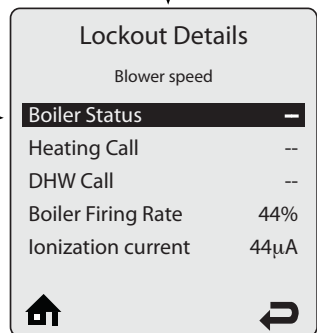



## CHAPTER 5 - ACVMAX OPERATION

### 5.10.1 Lockout Screen

If a problem occurs, the Lockout Screen replaces the Home Screen. The backlight will remain on until the lockout is reset.

Pressing any arrow button will return to the Home Screen so that additional troubleshooting can be performed. See *Sections 5.10.2 on page 22 and 5.10.3 on page 23* for a list of lockouts and descriptions.

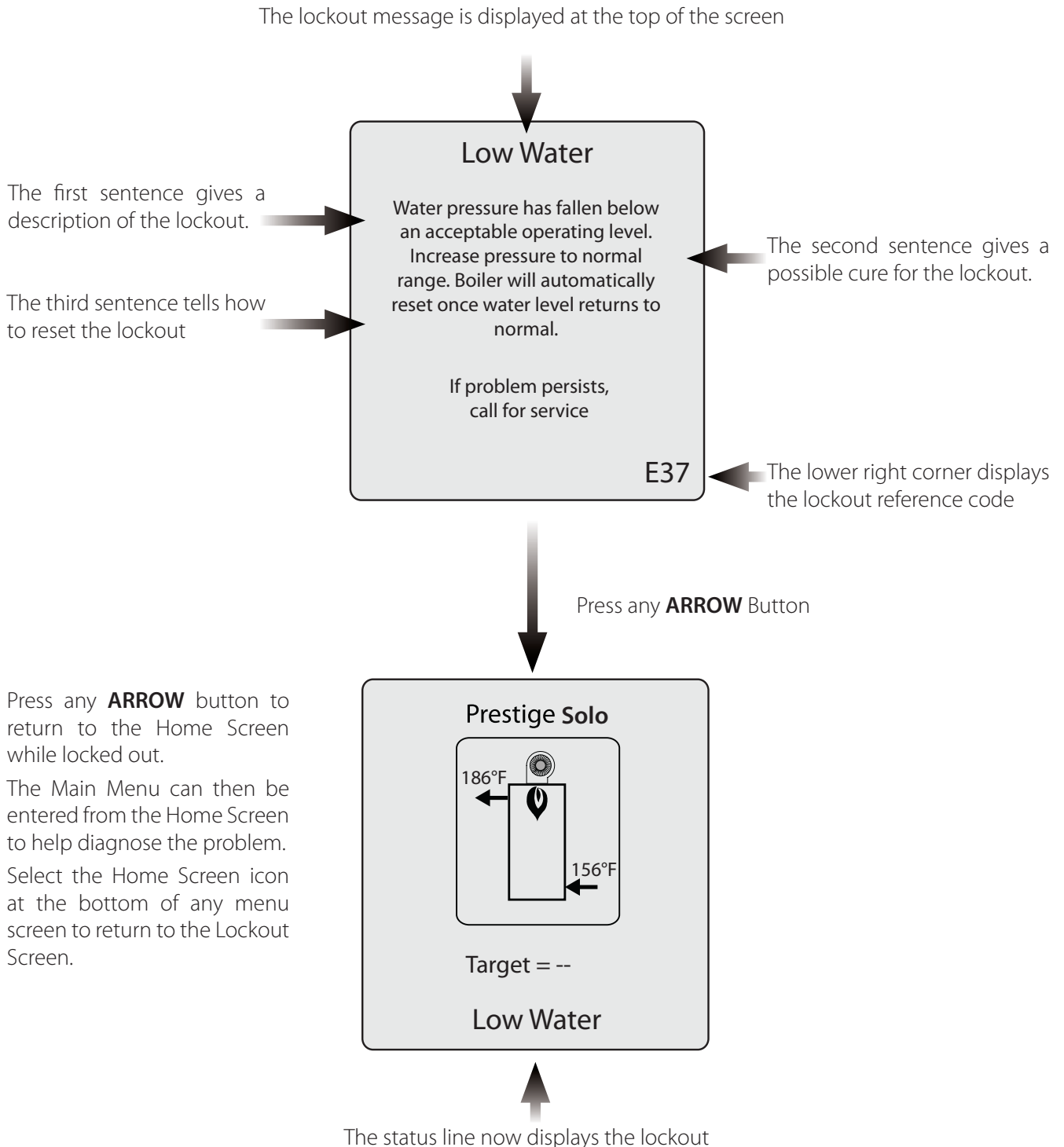

## CHAPTER 5 - ACVMAX OPERATION

### 5.10.2 Manual Reset Lockouts

Code	Lockout Message	Description
E1	Failed Ignition	The burner failed to light after 5 ignition attempts.
E2	False Flame	Flame detected prior to ignition.
E3	High Boiler Temperature	Boiler temperature has reached 210°F [99°C] or 102°F [39°C].
E5	Blower Speed	Blower is not at correct speed or speed signal is not being received by control module.
E8	Flame Circuit Error	Flame circuit test failed.
E9	Gas Valve Circuit Error	Gas valve circuit test failed.
E13	Reset Limit Reached	Resets are limited to 5 every 15 minutes.
E15	Sensor Drift	Supply or return sensor reading has drifted.
E16	Supply Sensor Stuck	Supply sensor reading is not changing.
E17	Return Sensor Stuck	Return sensor reading is not changing.
E18	Sensor Failure	Supply or return sensor reading changed very rapidly.
E19	Flame Failure During Startup Phase	Flame lost after startup
E21	Internal Control Fault	A / D conversion error.
E30	Supply Sensor Shorted	A short circuit has been detected in the boiler supply temperature sensor circuit.
E31	Supply Sensor Open	An open circuit has been detected in the boiler supply temperature sensor circuit.
E43	Return Sensor Shorted	A short circuit has been detected in the boiler return temperature sensor circuit.
E44	Return Sensor Open	An open circuit has been detected in the boiler return temperature sensor circuit.
E47	Water Pressure Sensor Error	Water pressure sensor is disconnected or broken.
E80	Return > Supply	Return temperature is higher than supply temperature.
E83	Delta T Protection	Excessive difference between boiler supply and return temperatures has occurred 5 times
E84	High Flue Temperature	Flue temperature has exceeded high limit 5 times
E87	External Limit Open	An external manual reset limit has opened

## CHAPTER 5 - ACVMAX OPERATION

### 5.10.3 Automatic Reset Blocking Lockouts

Code	Lockout Message	Description
E7	High Flue Temperature	Flue temperature exceeds high limit.
E12	Internal Control Fault	EEPROM misconfiguration.
E25	Internal Control Fault	CRC check error.
E32	DHW Sensor Shorted	A short circuit has been detected in the DHW temperature sensor circuit.
E33	DHW Sensor Open	An open circuit has been detected in the DHW temperature sensor circuit.
E34	Low Voltage	Line voltage has fallen below an acceptable operating level.
E37	Low Water	Water pressure has fallen below 7.2 psi.
E45	Flue Sensor Shorted	A short circuit has been detected in the boiler flue temperature sensor circuit.
E46	Flue Sensor Open	An open circuit has been detected in the boiler flue temperature sensor circuit.
E76	External Limit Open	An external automatic reset boiler limit has opened.
E77	High Mix Circuit Temperature	Mix circuit temperature exceeds Mix zone high limit setting.
E78	Mix Circuit Sensor Shorted	A short circuit has been detected in the mix circuit temperature sensor circuit.
E79	Mix Circuit Sensor Open	An open circuit has been detected in the mix circuit temperature sensor circuit.
E81	Sensor Drift	Supply and return temperatures are not equal.
E82	Delta T Protection	Excessive difference between the boiler supply and return temperatures.
E89	Incorrect Setting	A parameter setting is in conflict with another setting.
E90	Firmware Mismatch	Control module and display firmware versions are incompatible.
E91	System Sensor Shorted	A short circuit has been detected in the system temperature sensor circuit.
E92	System Sensor Open	An open circuit has been detected in the system temperature sensor circuit.
E93	Outdoor Sensor Shorted	A short circuit has been detected in the outdoor temperature sensor circuit.
E94	Internal Display Fault	Display memory error.
E95	Supply Sensor Error	Supply sensor reading is invalid.
E96	Outdoor Sensor Open	An open circuit has been detected in the outdoor temperature sensor circuit.
E97	Cascade Mismatch	Cascade configuration has changed.
E98	Cascade Bus Error	Communication with other boilers has been lost.
E99	Controller Bus Error	Communication between boiler display and control module has been lost.

**INTENTIONALLY LEFT BLANK**

## CHAPTER 6 - REPLACEMENT PARTS

### **WARNING**

- Replacement parts must be purchased through a local Triangle Tube distributor. When ordering a part, please provide the model number and description and/or part number of replacement part.
- Use only genuine Triangle Tube replacement parts to ensure warranty coverage and to avoid improper operation or damage to appliance.
- Contact Triangle Tube at 856-228-8881 or [www.triangletube.com](http://www.triangletube.com) for a list of distributors near you.

Fig. 3 - PRESTIGE Solo 80/110 Jacket Components

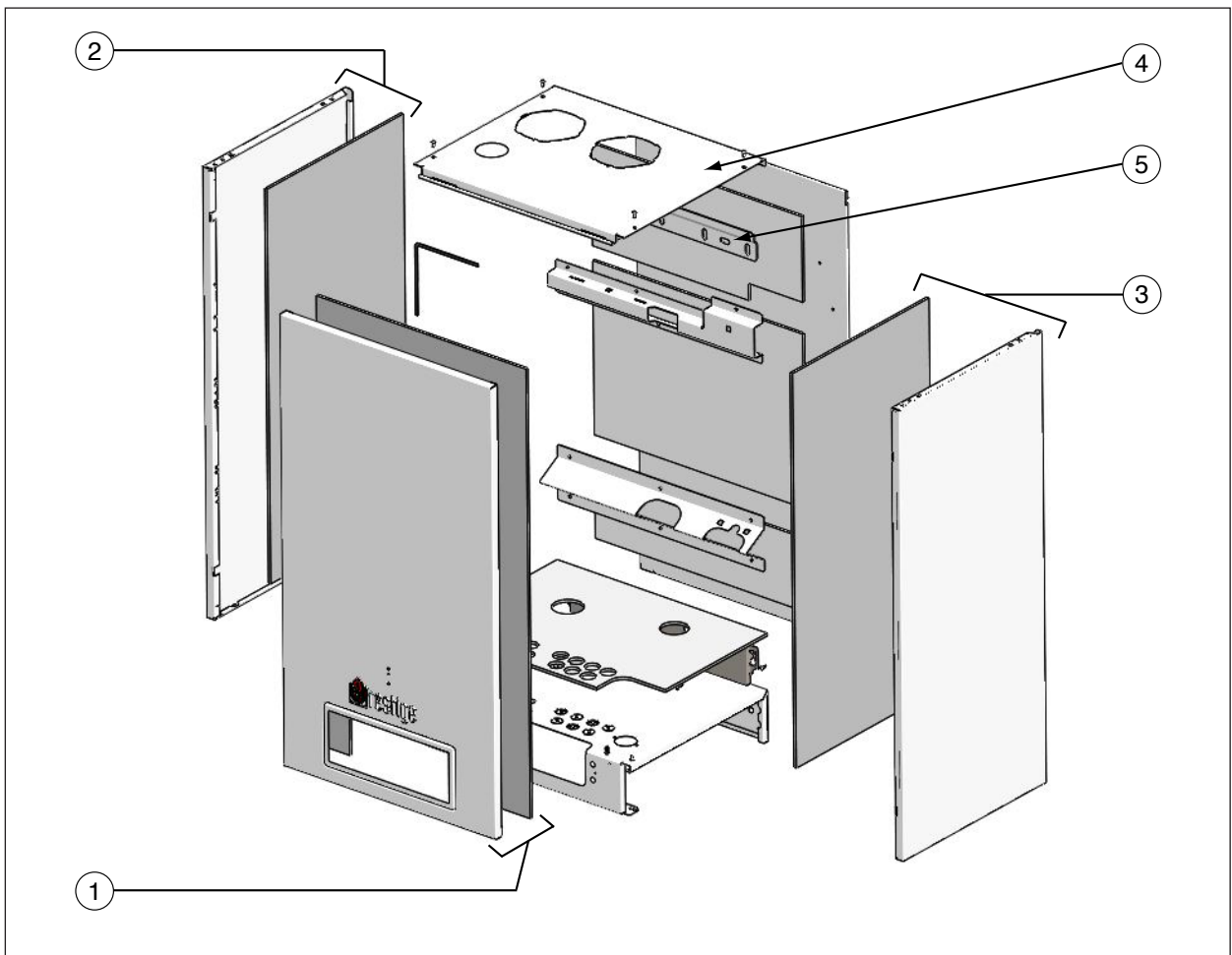

Item	Part #	Description
1	PAJKT01	Front Jacket Panel (with insulation)
2	PAJKT03	Left Side Jacket Panel (with insulation)
3	PAJKT21	Right Side Jacket Panel (with insulation)
4	PAJKT04	Top Panel
5	PSRKIT21	Wall Mounting Bracket with Hardware

Fig. 4 - PRESTIGE Solo 155/175/250 Jacket Components

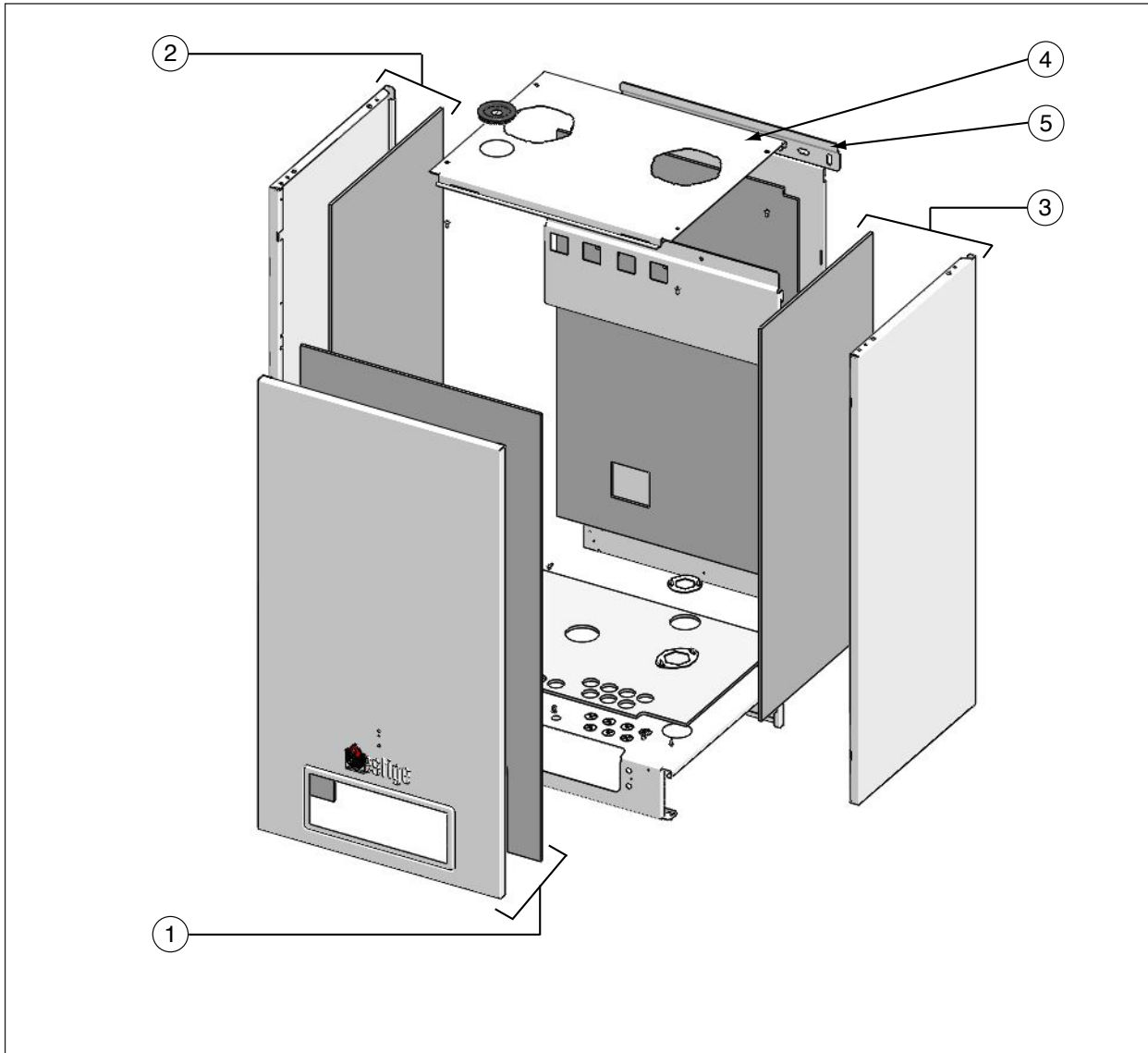

Item	Part #	Description
1	PAJKT01	Front Jacket Panel (with insulation)
2	PAJKT03	Left Side Jacket Panel (with insulation)
3	PAJKT21	Right Side Jacket Panel (with insulation)
4	PAJKT12	Top Panel
5	PSRKIT21	Wall Mounting Bracket with Hardware

Fig. 5 - PRESTIGE Solo 299/399 Jacket Components

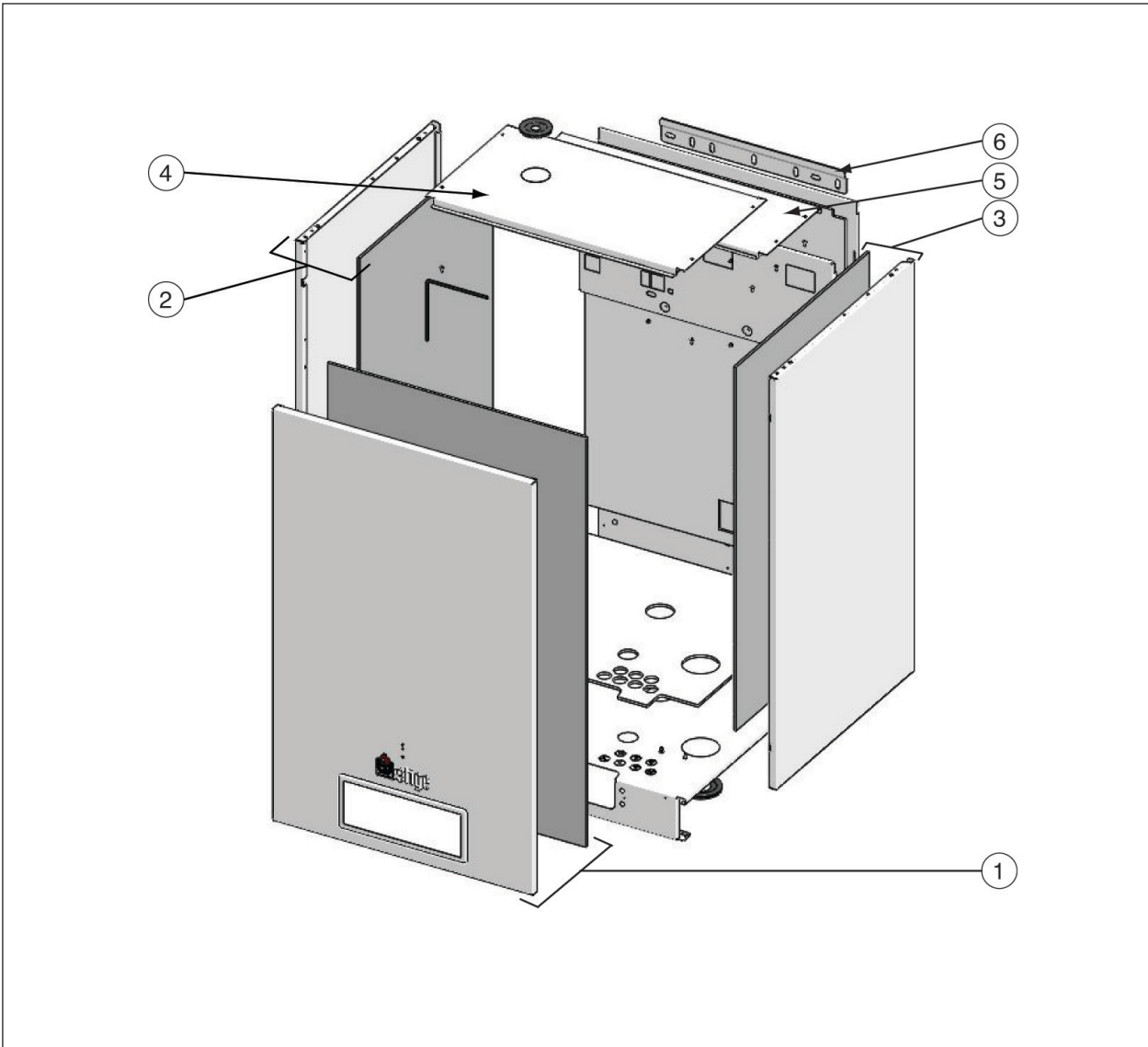

Item	Part #	Description
1	PAJKT15	Front Jacket Panel (with insulation)
2	PAJKT16	Left Side Jacket Panel (with insulation)
3	PAJKT22	Right Side Jacket Panel (with insulation)
4	PAJKT17	Top Panel - Front
5	PAJKT18	Top Panel - Rear
6	PSRKIT21	Wall Mounting Bracket with Hardware

## CHAPTER 6 - REPLACEMENT PARTS

Fig. 6 - PRESTIGE Excellence 110 Jacket Components

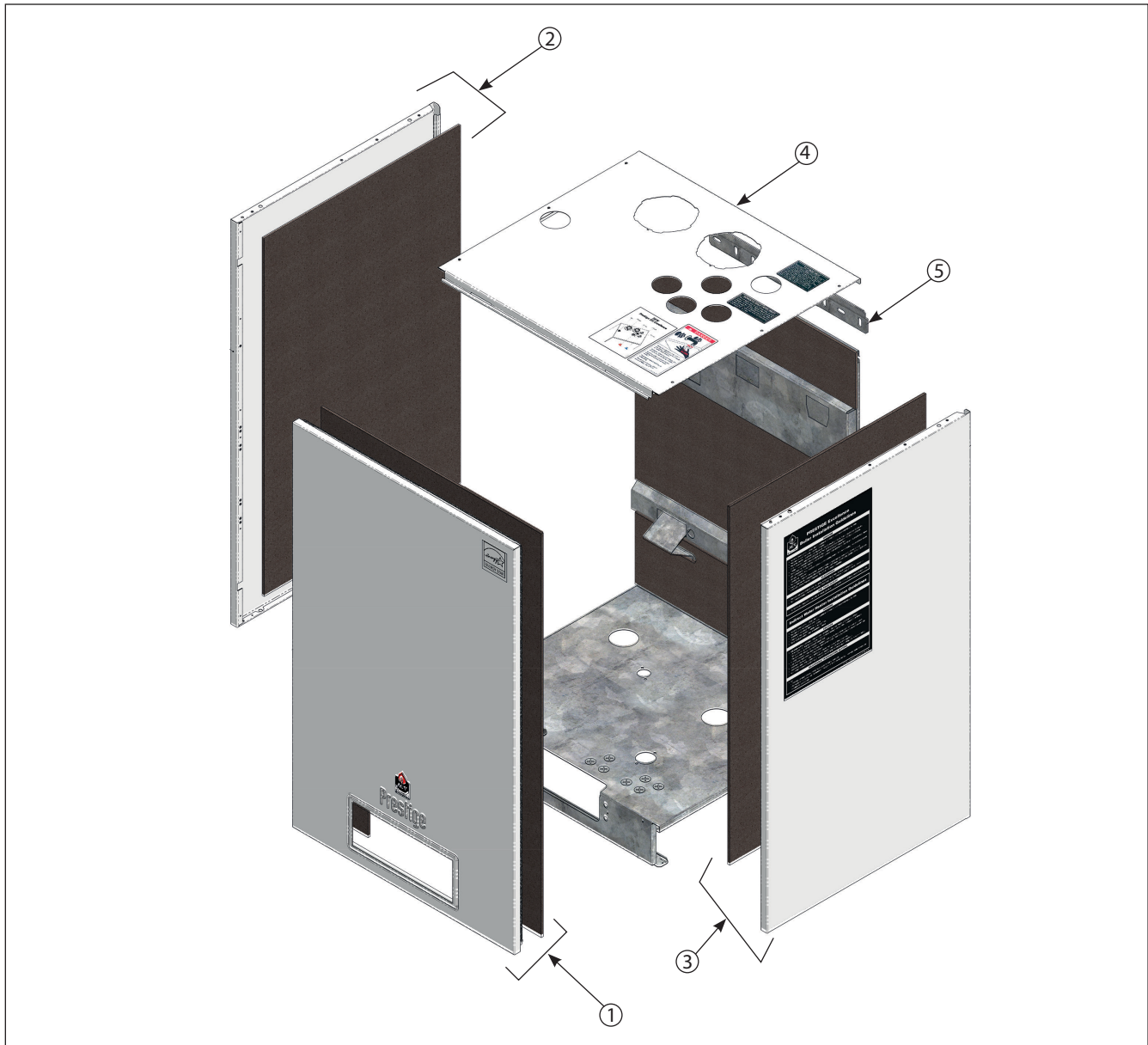

Item	Part #	Description
1	PAJKT15	Front Jacket Panel (with insulation)
2	PAJKT16	Left Side Jacket Panel (with insulation)
3	PAJKT22	Right Side Jacket Panel (with insulation)
4	PAJKT25	Top Panel
5	PSRKIT21	Wall Mounting Bracket with Hardware



## CHAPTER 6 - REPLACEMENT PARTS

Fig. 7 - PRESTIGE Solo 80/110 Internal Components

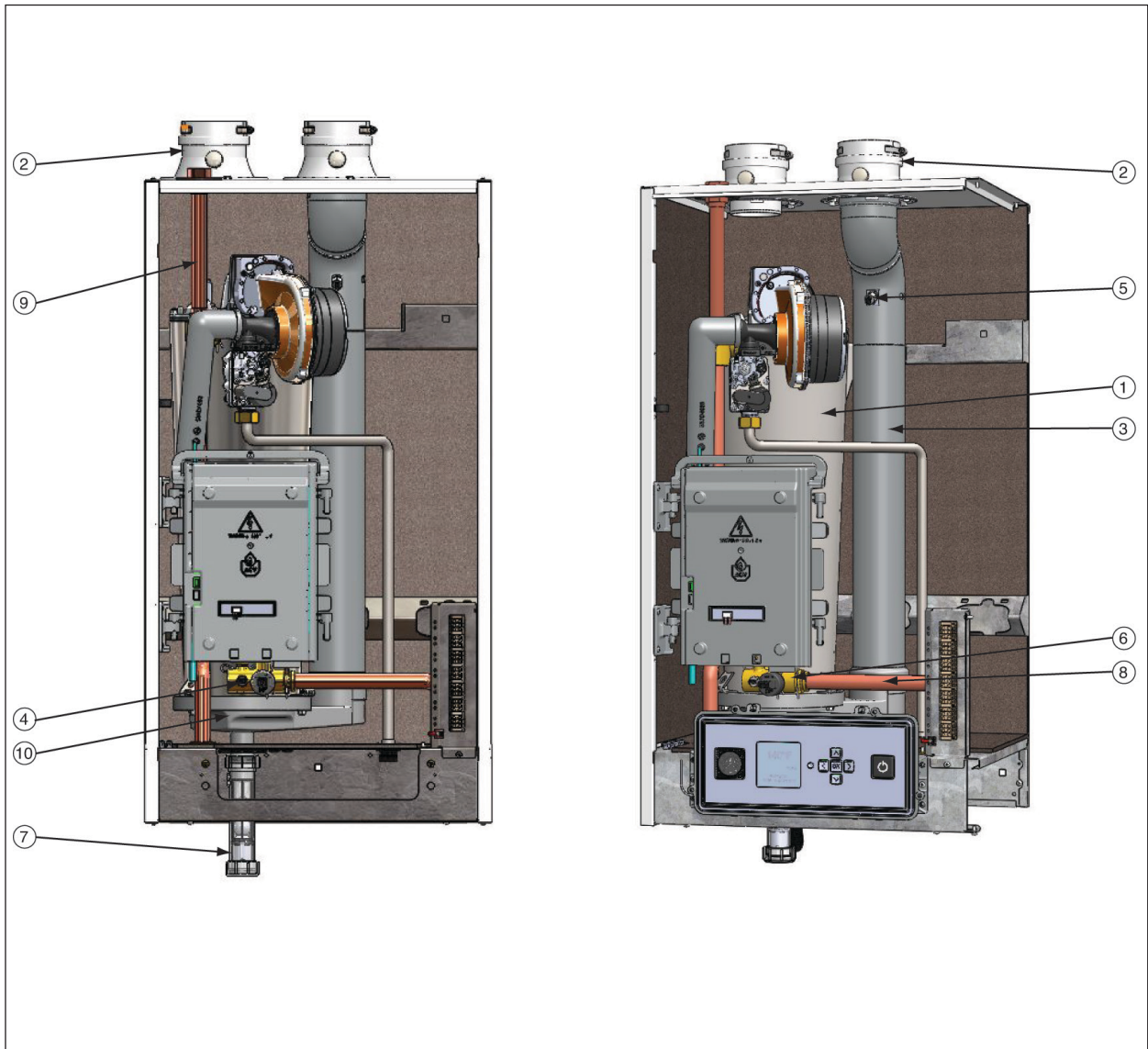

Item	Part #	Description
1	PARKIT90	Heat Exchanger Body
2	PTADPT07	Vent Outlet/Combustion Air Inlet Adapter
3	PARKIT02	Polypropylene Vent Pipe
4	PTRKIT123	Supply/Return Temperature Sensor
5	PARKIT01	Flue Temperature Sensor
6	PARKIT04	LWCO Pressure Sensor
7	PARKIT05	Condensate Drain Assembly
8	PARKIT06	Boiler Piping - Return Assembly
9	PARKIT07	Boiler Piping - Supply Assembly
10	PTRKIT119	Polypropylene Condensate Pan 80/100

## CHAPTER 6 - REPLACEMENT PARTS

Fig. 8 - PRESTIGE Solo 155/175/250 Internal Components

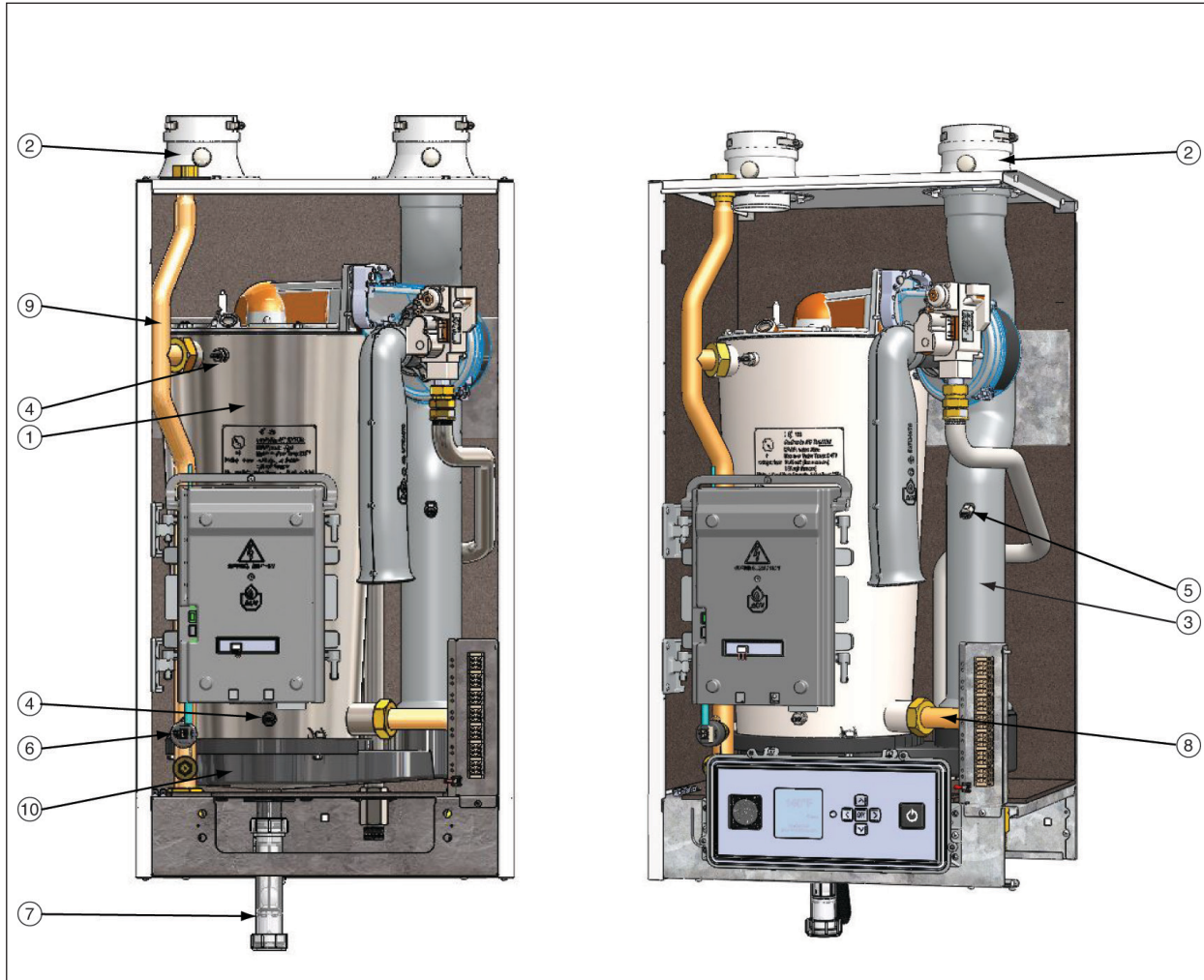

Item	Part #	Description
1	PARKIT91	Heat Exchanger Body Solo 155
	PARKIT92	Heat Exchanger Body Solo 175
	PARKIT93	Heat Exchanger Body Solo 250
2	PTADPT07	Vent Outlet/Combustion Air Inlet Adapter
3	PARKIT08	Polypropylene Vent Pipe
4	PTRKIT122	Supply/Return Temperature Sensor
5	PARKIT01	Flue Temperature Sensor
6	PARKIT04	LWCO Pressure Sensor
7	PSRKIT05	Condensate Drain Assembly
8	PARKIT46	Boiler Piping - Return Assembly
9	PARKIT47	Boiler Piping - Supply Assembly
10	PARKIT43	Polypropylene Condensate Pan Solo 155
	PTRKIT120	Polypropylene Condensate Pan Solo 175 & 250

## CHAPTER 6 - REPLACEMENT PARTS

Fig. 9 - PRESTIGE Solo 299/399 (●) Internal Components

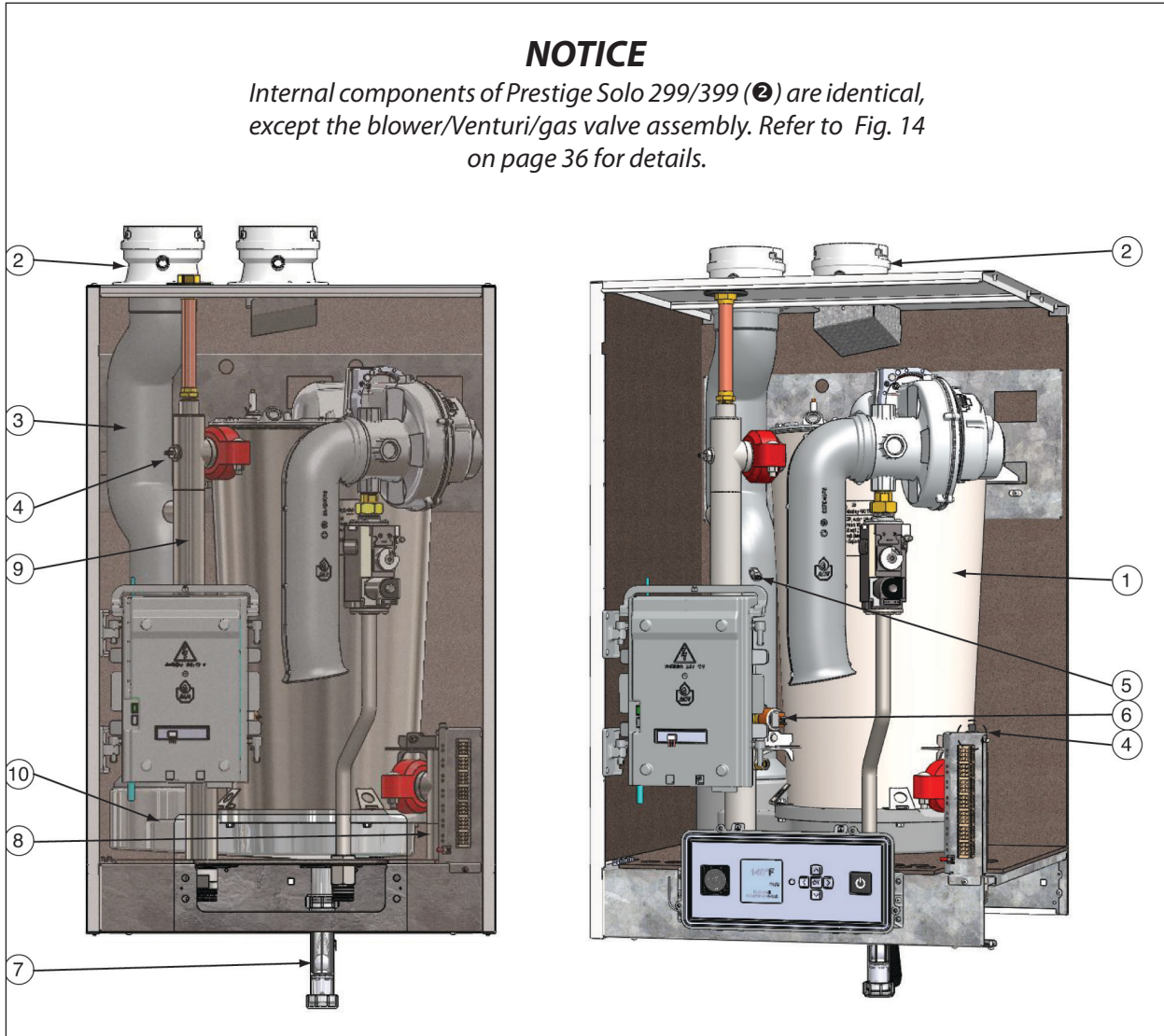

Item	Part #	Description
1	PARKIT94	Heat Exchanger Body Solo 299
	PARKIT95	Heat Exchanger Body Solo 399
2	PTADPT08	Vent Outlet/Combustion Air Inlet Adapter
3	PARKIT09	Polypropylene Vent Pipe
4	PARKIT78	Supply/Return Temperature Sensor
5	PARKIT01	Flue Temperature Sensor
6	PARKIT04	LWCO Pressure Sensor
7	PSRKIT05	Condensate Drain Assembly
8	PSRKIT48	Boiler Piping - Return Assembly
9	PSRKIT49	Boiler Piping - Supply Assembly
10	PTRKIT121	Polypropylene Condensate Pan Solo 299/399



## CHAPTER 6 - REPLACEMENT PARTS

Fig. 10 - PRESTIGE Excellence 110 Internal Components

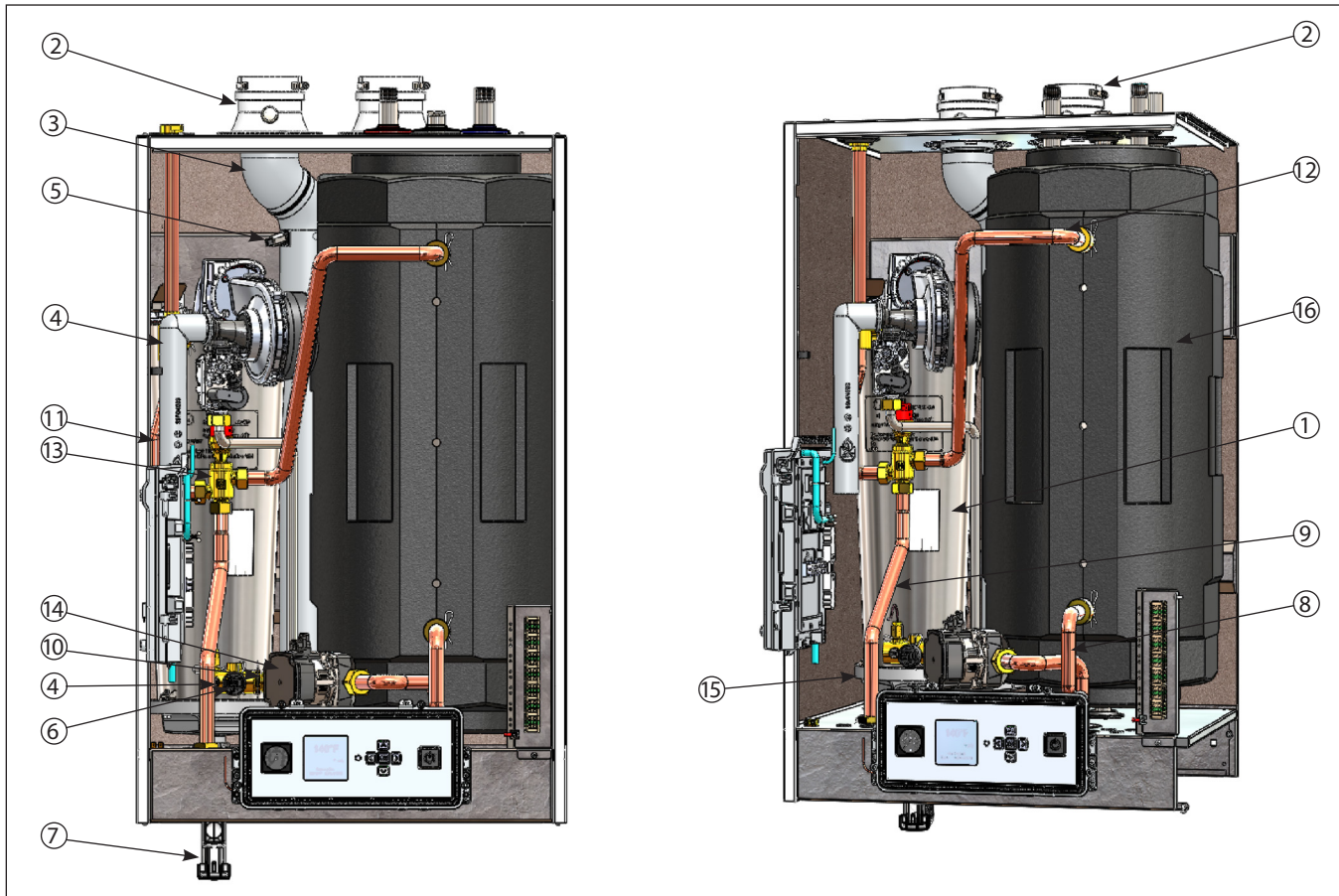

Item	Part #	Description
1	PARKIT90	Heat Exchanger Body
2	PTADPT07	Vent Outlet/Combustion Air Inlet Adapter
3	PARKIT03	Polypropylene Vent Pipe
4	PTRKIT123	Supply/Return Temperature Sensor
5	PARKIT01	Flue Temperature Sensor
6	PARKIT04	LWCO Pressure Sensor
7	PARKIT05	Condensate Drain Assembly
8	PARKIT36	Boiler Piping - CH/DHW Return Assembly
9	PARKIT38	Boiler Piping - CH Supply Assembly
10	PARKIT35	Boiler Piping - HX Return Assembly
11	PARKIT37	Boiler Piping - HX Supply Assembly
12	PARKIT39	Boiler Piping - DHW Supply Assembly
13	PARKIT23	Valve Assembly
14	PARKIT24	Circulator
15	PTRKIT119	Polypropylene Condensate Pan
16	PARKIT22	Excellence Water Heater Tank

## CHAPTER 6 - REPLACEMENT PARTS

Fig. 11 - PRESTIGE Solo 80/110 / Excellence 110 Burner Components

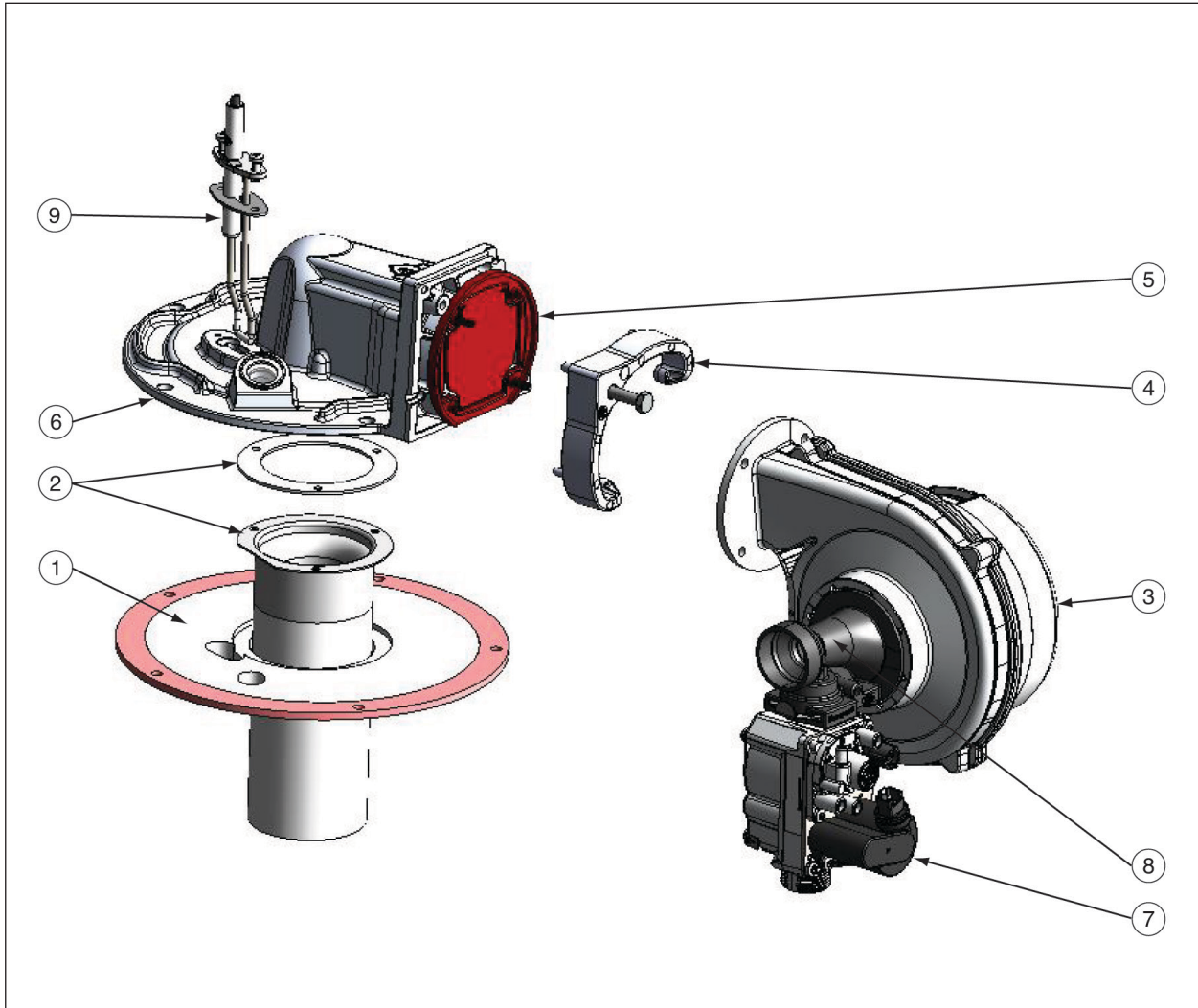

Item	Part #	Description
1	PARKIT12	Combustion Chamber 2-in-1 Insulation
2	PARKIT14	Burner Head Assembly (with Gasket)
3	PARKIT11	Blower Assembly (with Gasket)
4	PARKIT18	Blower Clamp
5	PARKIT19	Blower Gasket
6	PARKIT15	Burner Plate Assembly
7	PARKIT17	Gas Valve
8	PARKIT10	Venturi - Solo 80 (025)
	PARKIT20	Venturi - Solo 110/Excellence 110 (040)
9	PARKIT16	Igniter Assembly

Fig. 12 - PRESTIGE Solo 155/175/250 Burner Components

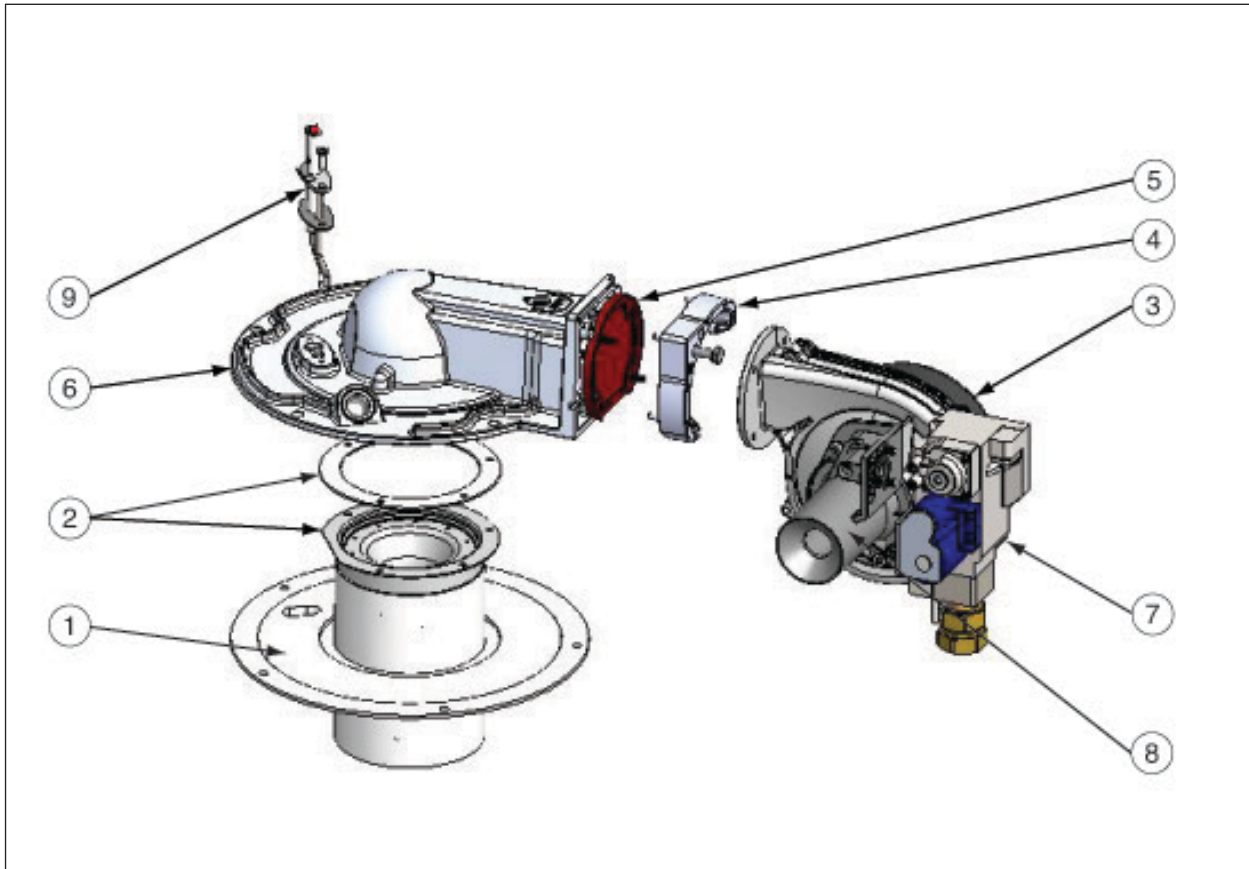

Item	Part #	Description
1	PARKIT42	Combustion Chamber 2-in-1 Insulation - Solo 155
	PARKIT52	Combustion Chamber 2-in-1 Insulation - Solo 175 & 250
2	PARKIT54	Burner Head Assembly (with Gasket)
3	PARKIT51	Blower Assembly (with Gasket) - Solo 155 & 175
	PARKIT70	Blower Assembly (with Gasket) - Solo 250
4	PARKIT18	Blower Clamp
5	PARKIT19	Blower Gasket
6	PARKIT45	Burner Plate Assembly - Solo 155
	PARKIT55	Burner Plate Assembly - Solo 175 & 250
7	PTRKIT111	Gas Valve
	PSRKIT81	Venturi - Solo 155 (002)
	PARKIT40	Venturi - Solo 175 (001)
8	PARKIT40	Venturi - Solo 175 (001)
	PSRKIT83	Venturi - Solo 250 (051)
9	PARKIT56	Igniter Assembly

## CHAPTER 6 - REPLACEMENT PARTS

Fig. 13 - PRESTIGE Solo 299/399 (●) Burner Components

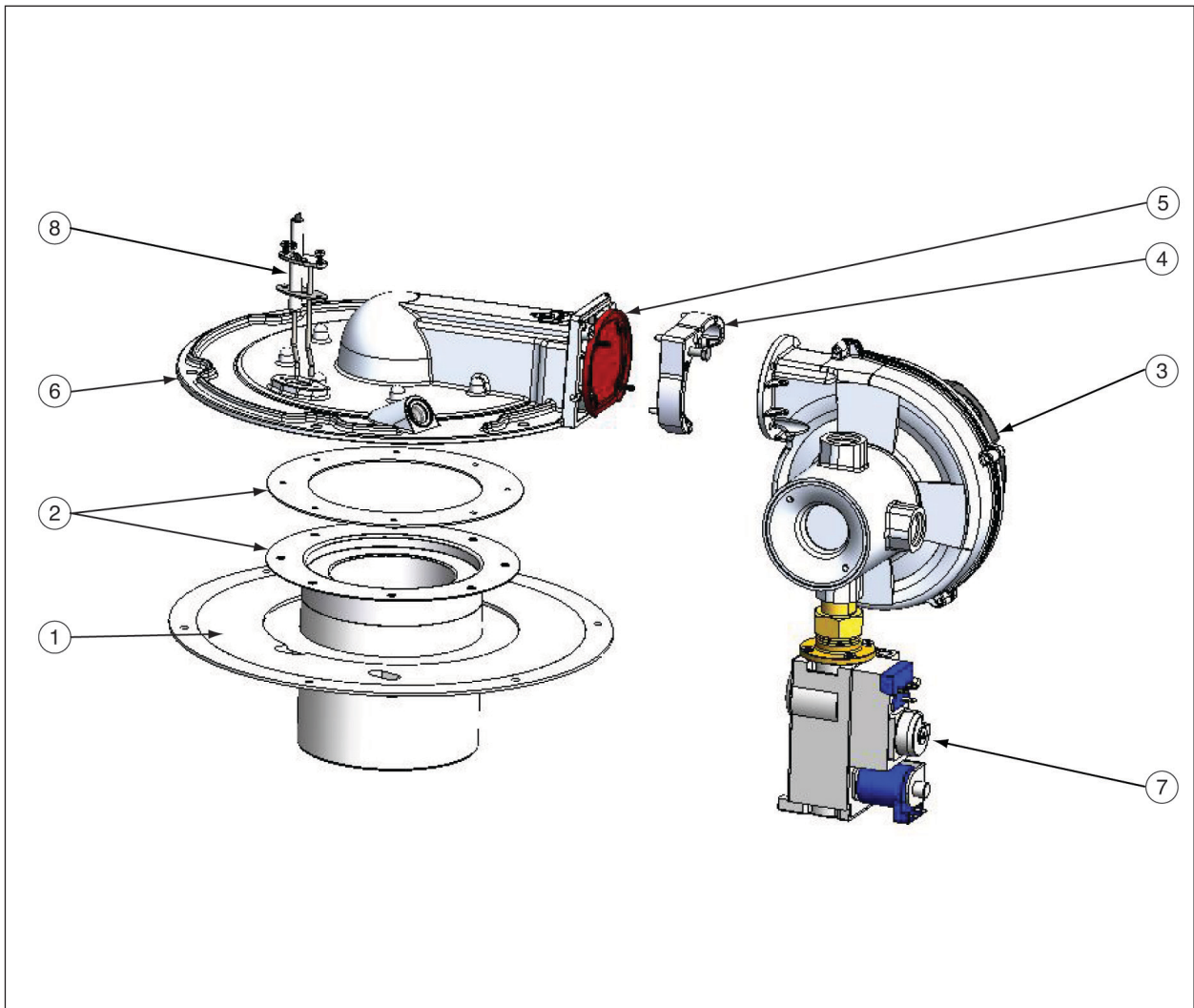

Item	Part #	Description
1	PARKIT72	Combustion Chamber 2-in-1 Insulation
2	PARKIT74	Burner Head Assembly (with Gasket)
3	PARKIT71	Blower Assembly (with Gasket)
4	PARKIT18	Blower Clamp
5	PARKIT19	Blower Gasket
6	PARKIT75	Burner Plate Assembly
7	PTRKIT112	Gas Valve
8	PARKIT16	Igniter Assembly

Fig. 14 - PRESTIGE Solo 299/399 (2) Burner Components

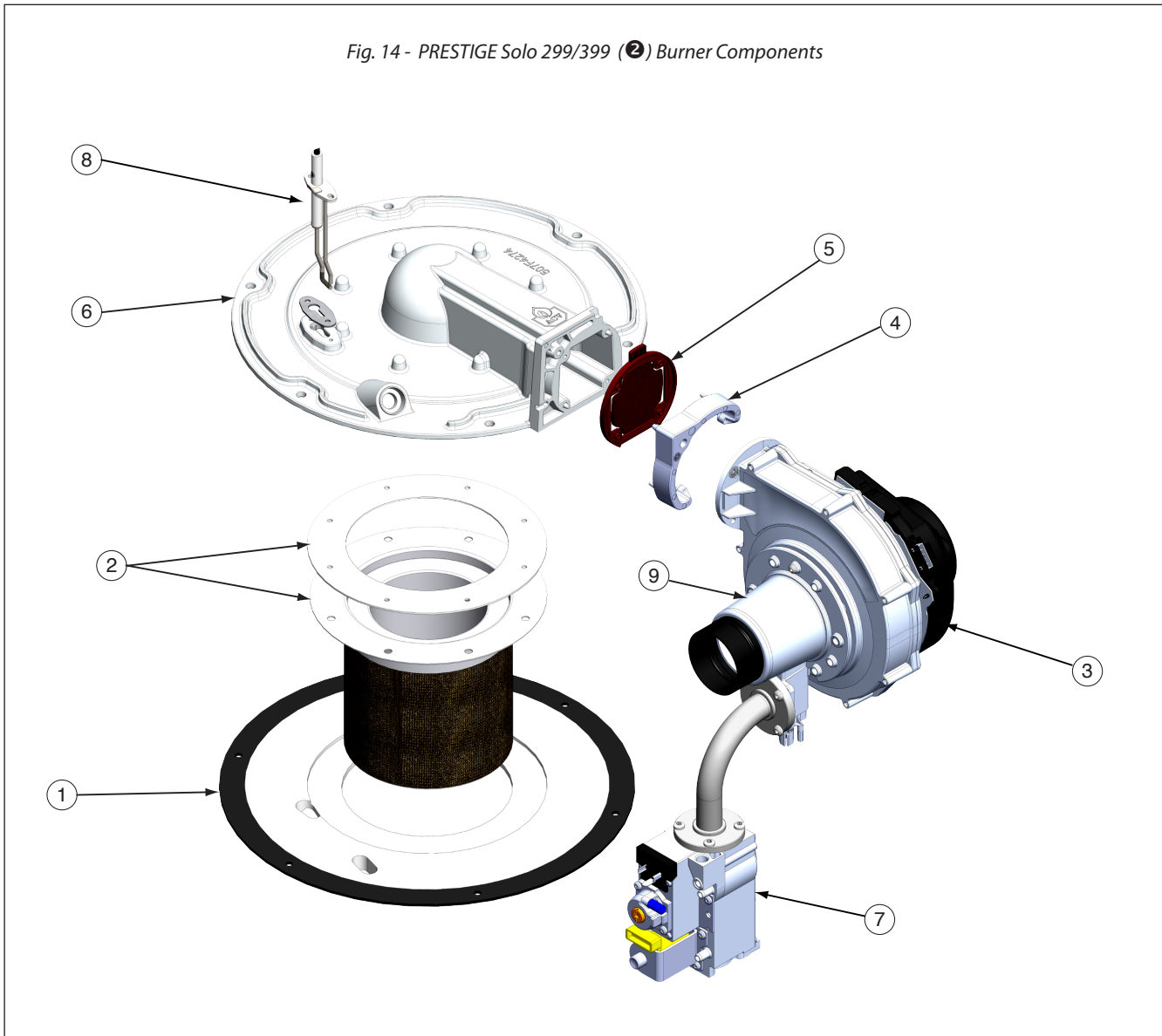

Item	Part #	Description
1	PARKIT72	Combustion Chamber 2-in-1 Insulation
2	PARKIT74	Burner Head Assembly (with Gasket)
3	TCRKIT16	Blower Assembly
4	PARKIT18	Blower Clamp
5	PARKIT19	Blower Gasket
6	PARKIT75	Burner Plate Assembly
7	TCRKIT18	Gas Valve
8	PARKIT16	Igniter Assembly
9	TCRKIT19	Venturi



Fig. 15 - PRESTIGE Solo Control & Display Enclosures

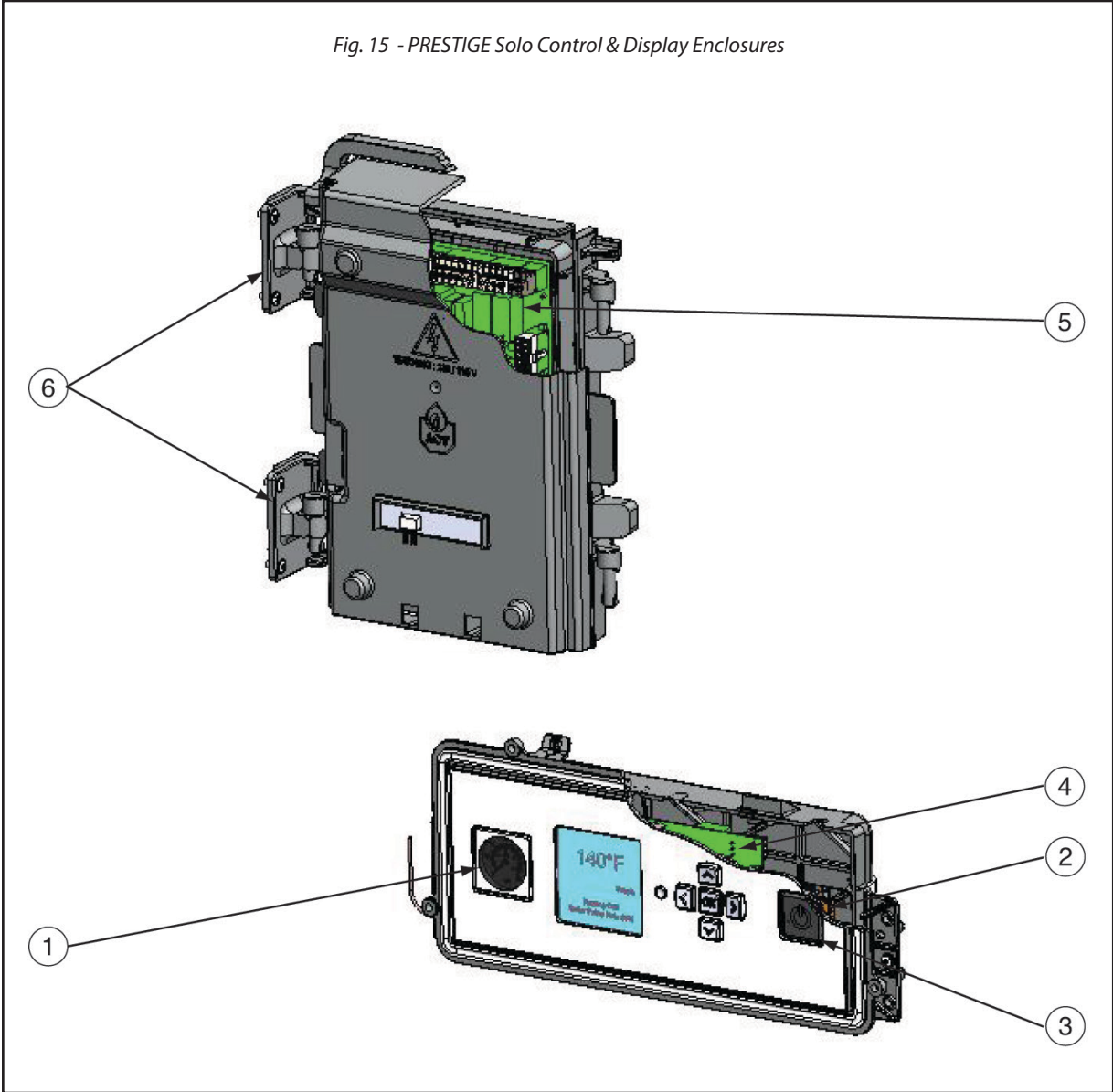

Item	Part #	Description
1	PTRKIT109	Pressure Gauge
2	PTSWI01	Power Switch
3	PTSWI02	Power Switch Cover
4	PARKIT101	Display Module
5	PARKIT100	Control Module (Universal when used with PARKIT101)
6	PAHNG01	Control Box Hinges



A series of horizontal dashed lines extending across the width of the page, providing a guide for handwriting practice.



A series of horizontal dotted lines for writing, starting from the top right of the notepad illustration and extending across the page.

## Additional quality water heating equipment available from Triangle Tube

### Maxi-Flo Pool and Spa Heat Exchangers



- Constructed of high quality corrosion resistant stainless steel (AISI 316) or titanium
- Specially designed built-in flow restrictor to assure maximum heat exchange
- Compact and light weight
- Available in 8 sizes to accommodate any size pool or spa

### SMART Indirect Fired Water Heaters



- Exclusive Tank-in-Tank design
- Stainless steel construction
- Available in 7 sizes
- Limited LIFETIME residential warranty
- 6 Year limited commercial warranty
- Self cleaning/self descaling design

### TTP Brazed Plate Heat Exchangers

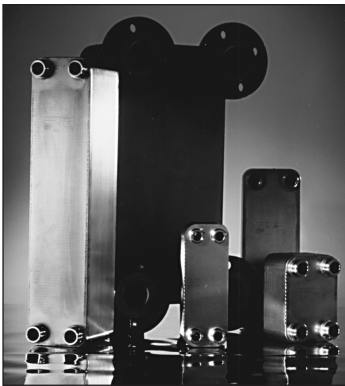

- For domestic water, snow melting, radiant floor
- Plates made of stainless steel, with 99.9 % copper brazing, ensuring a high resistance to corrosion
- Self cleaning and self descaling
- Computerized sizing available from Triangle Tube
- Available in capacities from 25,000 BTU/hr to 5,000,000 BTU/hr



Triangle Tube - 1240 Forest Parkway, Suite 100, West Deptford NJ 08066

Tel: (856) 228 8881 - Fax: (856) 228 3584 - E-mail: info.na@acv.com